

TM 5-4310-241-35P

DEPARTMENT OF THE ARMY TECHNICAL MANUAL

DIRECT AND GENERAL SUPPORT AND DEPOT
MAINTENANCE REPAIR PARTS AND SPECIAL TOOLS LIST

COMPRESSOR, RECIPROCATING: AIR; 5 CFM; 175 PSI;
HAND TRUCK MOUNTED; GASOLINE DRIVEN (CHAMPION
PNEUMATIC MODEL LP-512-ENG) LESS ENGINE
FSN 4310-861-9820 (CHAMPION PNEUMATIC MODEL
LP-51 2-ENG-1) LESS ENGINE FSN 4310-079-6290
RECEIVER MOUNTED, ELECTRIC DRIVEN; 3 PHASE; 2 HP;
60 HZ; AC; 208/416 V (CHAMPION PNEUMATIC
MODEL OEH-34-60-ENG-1) FSN 4310-861-9823
(CHAMPION PNEUMATIC MODEL OEH-34-60-ENG-4)
FSN 4310-695-1227 SINGLE-PHASE; 2 HP; 60 HZ; AC;
115/230 V (CHAMPION PNEUMATIC MODEL
OEH-34-60-ENG-2) FSN 4310-088-1855 (CHAMPION
PNEUMATIC MODEL OEH-34-60-ENG-3)
FSN 4310-075-3310



HEADQUARTERS, DEPARTMENT OF THE ARMY

MAY 1969

CHANGE }
 No. 1 }

HEADQUARTERS
 DEPARTMENT OF THE ARMY
 WASHINGTON, D. C., 13 February 1970

**Direct and General Support and
 Depot Maintenance Repair Parts and Special Tools List**

**COMPRESSOR, RECIPROCATING: AIR; 5 CFM; 175 PSI; HAND TRUCK MOUNTED;
 GASOLINE DRIVEN (CHAMPION PNEUMATIC MODEL LP-512-ENG)
 LESS ENGINE FSN 4310-861-9820
 (CHAMPION PNEUMATIC MODEL LP-512-ENG-1) LESS ENGINE FSN 4310-079-6290
 RECEIVER MOUNTED, ELECTRIC DRIVEN; 3 PHASE; 2 HP; 60 HZ; AC; 208/416V
 (CHAMPION PNEUMATIC MODEL OEH-34-60-ENG-1) FSN 4310-861-9823
 (CHAMPION PNEUMATIC MODEL OEH-34-60-ENG-4) FSN 4310-695-1227
 SINGLE-PHASE; 2 HP; 60 HZ; AC; 115/230V
 (CHAMPION PNEUMATIC MODEL OEH-34-60-ENG-2) FSN 4310-088-1855
 (CHAMPION PNEUMATIC MODEL OEH-34-60-ENG-3) FSN 4310-075-3310**

Current as of 7 October 1969

TM 5-4310-241-35P, 6 May 1969, is changed as follows:

Page v, paragraph 4e is added as follows:

e. Action change codes indicated in the left hand margin of the listing page denote the following:

N—Indicates an added item not included in previous publications.

C—Indicates a change in data.

F—Indicates a change in FSN only.

All changes, additions, or deletions of Federal stock numbers or manufacturer's part numbers within these changes should be appropriately reflected in the index.

Section II change, add, or delete as shown on the following pages.

PAGE	LINE	ACTION	(1)	(2)	(3)	(4)	(5)	(6)	(7)			(8)			(9)	(10)	(11)	
			SMR CODE INDEX NO.	FEDERAL STOCK NUMBER REFERENCE NO. & MFR CODE	USABLE ON CODE	DESCRIPTION REFERENCE NO & MFR CODE	USABLE ON CODE	UNIT OF ISSUE	QTY INC IN	QTY INC IN	30-DAY DS MAINT ALLOWANCE	30-DAY GS MAINT ALLOWANCE	1-YR ALW PER	DEPOT MAINT ALW- PER	ILLUS- TRATION NO	100 PER EQUIP	100 FIG EQUIP	(A) NO
					SECTION II. REPAIR PARTS FOR DIRECTS SUPPORT, GENERAL SUPPORT AND DEPOT MAINTENANCE 0306-TANKS, LINES, FITTINGS													
C	3		P 00043	4310-369-7405														
									*	*	*	*	*	*		3	3	
C	4		P 00048	2910-014-6964														
									*	*	2	*	*	2	10	6		
C			P 00054	2990-012-2557														
									*	2	2	*	2	2	20	20		
C	8		P 00113	4310-012-2254														
									*	*	2	*	*	2	10	6		
C	38		00560	4310-860-0035														
39		DELETE	00561	4310-838-9846														
		DELETE	00562															
C	40		PO 00584	4310-012-2235														
									*	*	*	*	*	*	3	3		
F	40	DELETE FSN	00590															
F	41		00594	2990-105-2596														
C	46		P 00659	4730-103-5461														
									*	*	2	*	*	2	10	6		

By Order of the Secretary of the Army:

W. C. WESTMORELAND,
*General, United States Army,
Chief of Staff.*

Official:

KENNETH G. WICKHAM,
*Major General, United States Army,
The Adjutant General.*

Distribution:

To be distributed in accordance with DA Form 12-25, See I (qty rqr Block No. 7), Direct and General Support requirements for Air Compressors, 5 CFM.

*U.S. GOVERNMENT PRINTING OFFICE: 1970-390-940/1484



**DIRECT AND GENERAL SUPPORT AND DEPOT MAINTENANCE REPAIR PARTS
AND SPECIAL TOOLS LIST**

**COMPRESSOR, RECIPROCATING: AIR; 5 CFM; 175 PSI;
HAND TRUCK MOUNTED; GASOLINE DRIVEN (CHAMPION
PNEUMATIC MODEL LP-512-ENG) LESS ENGINE FSN
4310-861-9820 (CHAMPION PNEUMATIC MODEL LP-512-
ENG-1) LESS ENGINE FSN 4310-079-6290 RECEIVER
MOUNTED, ELECTRIC DRIVEN; 3 PHASE; 2 HP; 60 HZ;
AC; 208/416 V (CHAMPION PNEUMATIC MODEL OEH-34-
60-ENG-1) FSN 4310-861-9823 (CHAMPION PNEUMATIC
MODEL OEH-34-60-ENG-4) FSN 4310-695-1227 SINGLE-
PHASE; 2 HP; 60 HZ; AC; 11 5/230 V (CHAMPION
PNEUMATIC MODEL OEH-34-60-ENG-2) FSN 4310-088-
1855 (CHAMPION PNEUMATIC MODEL OEH-34-60+ENG-3)
FSN 4310-075-3310**

Current as of 24 March 1969

	Paragraph	Page
SECTION I. INTRODUCTION		
Scope-----	1	iii
General-----	2	iii
Explanation of columns-----	3	iii
Special information -----	4	iv
How to locate repair parts -----	5	v
Abbreviations -----	6	v
Federal supply codes for manufacturers -----	7	v
Recommendations for maintenance manual improvements -----	8	v
II. REPAIR PARTS FOR DS, GS AND DEPOT MAINTENANCE		
Group 01. Engine		
0100 Engine Assembly -----		1
0102 Crankshaft -----		2
03. Fuel System		
0306 Tanks, lines, fittings -----		2
04. Exhaust System		
0401 Muffler and pipes -----		4
10. Front Axle		
1000 Front axle assembly -----		4
13. Wheel and Tracks		
1811 Wheel assembly -----		4
1819 Tires, tubes -----		6

* This manual together with TM 5-4310-241-20P, 6 May 1969, supersedes TM 5-4310-241-25P, 24 October 1962, 5 May 1965.

Group 15. Frame	
1501 Frame assembly	7
22. Body Chassis and Hull, and Accessory Items	
2202 Accessory items	9
2210 Data plates and instruction holders	10
40. Electric Motors and Generators (Other Than Engine Accessories)	
4000 Motor assemblies	11
4001 Rotor assemblies	12
4002 Stator assemblies	12
4004 Ventilating system	13
4005 Frame support and housing	13
4006 Starting devices	16
4007 Drive components	16
4010 Master or auxiliary Control assembly	16
4012 Switches	26
47. Gages (Non-Electrical) Weighing and Measuring Devices	
4702 Gages mountings, lines and fittings	27
50. Pneumatic Equipment	
5000 Air compressor assembly	27
5001 Crankcase, block, cylinder head	30
5002 Crankshaft	32
5004 Piston, connecting rods and rotors	33
5005 Valves, camshafts and timing mechanism	36
5006 Lubrication system	37
5007 Compressor drive	38
5008 Air intake	40
5009 Unloader system components	41
5010 Compressor cooling	46
5014 Air receiver	48
5015 Air discharge system	50
95. General Use Standardized Parts	
9501 Bulk material	51
99. Parts Peculiar	
9901 Multi-listed parts	52
SECTION III. SPECIAL TOOLS, TEST AND SUPPORT EQUIPMENT FOR	
DS,GS,ANDDEPOT MAINTENANCE NOT APPLICABLE	
IV. FEDERAL STOCK NUMBER AND REFERENCE NUMBER INDEX	75

SECTION I

INTRODUCTION

1. Scope

This manual lists repair parts required for the performance of direct support, general support, and depot maintenance of the air compressor.

2. General

a. The repair parts list is arranged as follows:

(1) Individual parts and major assemblies are listed alphabetically by item name within the numbered functional groups.

(2) Assembly components and subassemblies are indented and listed alphabetically by item name under major assemblies,

b. This Repair Parts and Special Tools List is divided into the following sections:

(1) *Repair Parts-Section II*. A list of repair parts authorized for the performance of maintenance at the direct support, general support, and depot level.

(2) *Special Tools, Test and Support Equipment-section III*. A list of special tools, test and support equipment authorized for the performance of maintenance at the direct support, general support, and depot level. Not Applicable.

(3) *Federal Stock Number and Reference Number Index-Section IV*. A list of Federal stock numbers followed by reference numbers in ascending alpha-numeric sequence cross-referenced to index number.

3. Explanation of Columns

The following provides an explanation of columns in the tabular lists in Sections II and III:

a. *Source, Maintenance, and Recoverability Codes (SMR), Column (1)*.

(1) Source code, indicates the selection status and source for the listed item. Source codes used are:

Code	Explanation
P	Applied to repair parts which are stocked in or supplied from DSA/GSA or Army supply system, and authorized for use at indicated maintenance categories.

Code	Explanation
M	Applied to repair parts which are not procured or stocked but are to be manufactured at indicated maintenance categories.
A	Applied to assemblies which are not procured or stocked as such but made up of two or more units, each of which carry individual stock numbers and descriptions and are procured and stocked and can be assembled by units at indicated maintenance categories.
X	Applied to parts and assemblies which are not procured or stocked, the mortality of which is normally below that of the applicable end item, and the failure of which should result in retirement of the end item from the supply System.
X1	Applied to repair parts which are not procured or stocked, the requirement for which will be supplied by use of the next higher assembly or components.
X2	Applied to repair parts which are not stocked. The indicated maintenance category requiring such repair parts will attempt to obtain them through cannibalization; if not obtainable through cannibalization, such repair parts will be requisitioned with supporting justification through normal supply channels.
C	Applied to repair parts authorized for local procurements. If not obtainable from local procurement, such repair parts will be requisitioned through normal supply channels with a supporting statement of nonavailability from local procurement
G	Applied to major assemblies that are procured with PEMA (Procurement Equipment Missile Army) funds for initial issue only to be used as exchange assemblies at DSU and GSU maintenance level. These assemblies will not be stocked above DSU and GSU level or returned to depot supply level.

Note. Source code is not shown on common hardware items known to be readily available in Army supply channels and through local procurement.

(2) Maintenance code, indicates the lowest category of maintenance authorized to install the listed item. The maintenance level codes are:

Code	Explanation
O	Organizational maintenance
F	Direct maintenance
H	General support maintenance
D	Depot maintenance

(3) Recoverability code, indicates whether unserviceable items should be returned for recovery or salvage. Items not coded are expendable. Recoverability codes are:

Code	Explanation
R	Applied to repair parts and assemblies which are economically repairable at DSU and GSU activities and normally are furnished by supply on an exchange basis.
T	Applied to high dollar value recoverable repair parts which are subject to special handling and are issued on an exchange basis. Such repair parts normally are repaired or overhauled at depot maintenance activities.
U	Applied to repair parts specifically selected for salvage by reclamation units because of precious metal content, critical materials, high dollar value reusable casings or castings.

(4) This column also lists, below the SMR code, an index number for each item in ascending numerical sequence, which is used to locate items in the publication when the Federal stock number and/or reference number is known.

b. Federal Stock Number, Column (2). This column indicates the Federal stock number for the item.

c. Description, Column (3). This column indicates the Federal item name and any additional description of the item required. A part number or other reference number is followed by the applicable five-digit Federal supply code for manufacturers in parentheses. Material required for manufacture or fabrication is identified.

d. Unit of Issue, Column (4). This column indicates the unit used as basis for issue, e.g., ea, pr, ft, yd, etc.

e. Quantity Incorporated in Unit Pack, Column (5). This column indicates the actual quantity contained in the unit pack.

f. Quantity Incorporated in Unit, Column (6). This column indicates the quantity of the item used in the functional group.

g. Thirty-Day DS/GS Maintenance Allowances, Columns (7) and (8).

(1) The allowance columns are divided into three subcolumns. Indicated in each subcolumn is the quantity of items authorized for the number of equipments supported. Items authorized for use as required but not for initial stockage are identified with an asterisk in the allowance column.

(2) The quantitative allowances for DS/GS levels of maintenance will represent initial stockage for a 30-day period for the number of equipments supported.

(3) Determination of the total quantity of parts required for maintenance of more than 100 of these equipments can be accomplished by converting the equipment quantity to a decimal factor by placing a decimal point before the next to last digit of the number to indicate hundredths, and multiplying the decimal factor by the parts quantity authorized in the 51-100 allowance column. Example, authorized allowance for 51-100 equipments is 40; for 150 equipments multiply 40 by 1.50 or 60 parts required.

h. One-Year Allowances Per 100 Equipments/Contingency Planning Purposes, Column (9). This column indicates the quantity required for distribution and contingency planning purposes. The range of items indicates total quantities of all authorized items required to provide for adequate support of 100 equipments for one year.

i. Depot Maintenance Allowance Per 100 Equipments, Column (10). This column indicates the quantity authorized for depot maintenance of 100 equipments. Items authorized for use but not for initial stockage are identified with an asterisk in the allowance column.

j. Illustration, Column (11).

(1) *Figure number.* Indicates the figure number of the illustration in which the item is shown.

(2) *Item number.* Indicates the callout number used to reference the item in the illustration.

4. Special Information

a. Identifications of the usable on codes of this publication are:

Code	Used on
A ----	Compressor, model LP-512-ENG, Gasoline driven
B ----	Compressor, model OEH-34-60-ENG-1, Electric motor driven
C ----	Compressor, model OEH-3440-ENG-2, Electric motor driven
D...	Compressor, model OEH-34-60-ENG-3, Electric motor driven
E ----	Compressor, model OEH-34-60-ENG-4, Electric motor driven
F ____	Compressor, model LP-512-ENG-1, Gasoline driven

Repair parts not symbolized applicable all models. Refer to TM 5-2805-206-24P for information on repair parts and allowances for the MIL STD ENGINE EA08-1 and 1A08-2.

b. Repair parts mortality has been based on 1,000 hours of operation per year.

c. Parts which require manufacture or assembly at a category higher than that authorized for installation will indicate in the source column the higher category.

d. The following publications pertain to the air compressor and its components:

- TM 5-4310-241-15 Organizational, DS, GS, and depot maintenance manual.
- TM 5-4310-241-20P Organizational maintenance repair parts and special tool lists.
- LO 5-4310-241-15 Lubrication Order.

5. How to Locate Repair Parts

a. When Federal stock number or reference number is unknown:

(1) *First.* Using the table of contents, determine the functional group within which the repair part belongs.

(2) *Second.* Find the illustration covering the functional group to which the repair part belongs.

(3) *Third.* Identify the repair part on the illustration, and note the illustration figure and item number of the repair part.

(4) *Fourth.* Using the repair parts listing, find the functional group to which the repair part belongs and locate the illustration figure and item number noted on the illustration.

b. When Federal stock number or reference number is known:

(1) *First.* Using the index of Federal stock numbers and reference numbers, find the pertinent Federal stock number or reference number. This index is in ascending alphanumeric sequence cross-referenced to an index number.

(2) *Second.* Using the repair part listing, find the index number referenced in the index of Federal stock numbers and reference numbers.

6. Abbreviations

- awg ----- American Wire Gage
- dia ----- diameter
- ea ----- each
- ft ----- feet (foot)
- grp ----- group
- hp ----- horsepower
- id ----- inside diameter
- in. ----- inch
- lb ----- pound (s)
- lg ----- long
- lh ----- left hand
- max ----- maximum
- mtg ----- mounting
- No. ----- number
- od ----- outside diameter

- psi ----- pounds per square inch
- rh ----- right hand
- thd ----- thread
- thk ----- thick
- v ----- volt(s)
- vac ----- volt-alternating current
- w/ ----- with
- w ----- watts, wide, (width)

7. Federal Supply Codes for Manufacturers

- 08070 ---- Tru-Flate Division Parker-Hannifin Corp.
- 08645 ---- Briggs and Stratton Corp.
- 11431 ---- Gleason Corp.
- 11568 ---- Champion Pneumatic Machinery Co., Inc.
- 14959 ---- Crane Co.
- 21810 ---- Federal Pacific Electric Co.
- 23826 ---- Furnas Electric Co.
- 25472 ---- Goodrich B. F. Co., The
- 26403 ---- Grinnell Co., Inc.
- 30327 ---- Imperial-Eastman Corp.
- 38151 ---- Marathon Electric Mfg. Corp.
- 43334 ---- New Departure-Hyatt Bearings Division
General Motors Corp.
- 60038 ---- Timken Roller Bearing Co.
- 70925 ---- Bijur Lubricating Corp.
- 71342 ---- Cash A. W. Valve Mfg. Corp.
- 72800 ---- Eaton Yale and Towne, Inc. Reliance
Division
- 72962 ---- Elastic Stop Nut Corp. of America
- 73559 ---- Carling Electric, Inc.
- 74545 ---- Hubbell Harvey, Inc.
- 75336 ---- Kingston F. C. Co.
- 79150 ---- Victor Mfg. and Gasket Co.
- 79807 ---- Wrought Washer Mfg. Co.
- 80201 ---- Chicago Rawhide Mfg. Co.
- 81336 ---- Chief of Engineers
- 86285 ---- Cornell E. H. Co.
- 86283 ---- Roth E. Co.
- 87005 ---- Madden Brass Products Co. Division of
Robinair Mfg. Corp.
- 87764 ---- Universal Screw and Bolt Co.
- 91895 ---- Marshall Brass Co.
- 92976 ---- Kaddis A. G. Screw Products, Inc.
- 94894 ---- Milton Manufacturing Co., Inc.
- 96906 ---- Military Standards Promulgated by
Standardization Division Directorate of
Logistic Services DSA
- 97464 ---- Industrial Retaining Ring Co.

8. Recommendations for Maintenance Manual improvement

Report of errors, omissions, and recommendations for improving this publication by the individual user is encouraged. Reports should be submitted on DA Form 2028 (Recommended Changes to DA Publications) and forwarded direct to Commanding General, U. S. Army Mobility Equipment Command, ATTN: AMSME-MPP, 4300 Goodfellow Boulevard, St. Louis, Mo. 63120.

(1) SMR CODE INDEX NO.	(2) FEDERAL STOCK NUMBER	(3) DESCRIPTION REFERENCE NO. & MFR. CODE	(4) USABLE ON CODE UNIT OF ISSUE	(5) QTY INC IN UNIT PACK	(6) QTY INC IN UNIT	(7) 30-DAY DS MAINT ALLOWANCE (A)	(8) 30-DAY GS MAINT ALLOWANCE (A)	(9) 1-YR DEPOT MAINT ALLOWANCE (B)	(10) 1-YR DEPOT MAINT ALLOWANCE (C)	(11) ILLUS- TRATION (A)	(12) ITEM NO.				
SECTION II - REPAIR PARTS FOR DIRECT SUPPORT GENERAL SUPPORT AND DEPOT MAINTENANCE															
00001		GROUP 01 - ENGINE													
00002		0100 - ENGINE ASSEMBLY													
X2 O 00003	2805-993-4199	BRACKET,ENGINE MOUNTING M502A (11568)	AF EA		2					6	5				
P O T 00004	2805-601-5181	ENGINE,GASOLINE: 1 1/2HP,MILITARY STANDARD ENGINE,MODEL 1A08-1 1A08-1 (81336)	A EA		1	*	*	2	*	*	2	10	6	6	1
P O T 00005	2805-714-8552	ENGINE,GASOLINE: 1 1/2 HP,MILITARY STANDARD ENGINE,MODEL 1A08-2 1A08-2 (81336)	F EA		1	*	*	2	*	*	2	10	6	6	1
O 00006	5310-050-3275	NUT,SELF-LOCKING,HEXAGON: ENGINE MTG,BRACKET TO FRAME	AF EA		4	*	*	*	*	*	*	*	*	6	10
O 00007	5305-269-3211	SCREW,CAP,HEXAGON HEAD: ENGINE MTG BRACKET FRAME, CROSSBAR AND SPACER	A EA		2	*	*	*	*	*	*	*	*	6	8
O 00008	5305-068-0502	SCREW,CAP,HEXAGON HEAD: ENGINE MTG,BRACKET TO ENGINE	AF EA		12	*	*	*	*	*	*	*	*	6	7
O 00009	5305-021-5466	SCREW,CAP,HEXAGON HEAD: ENGINE MTG,BRACKET TO FRAME	F EA		4	*	*	*	*	*	*	*	*	6	8
O 00010	5305-021-5466	SCREW,CAP,HEXAGON HEAD: ENGINE MTG,BRACKET TO FRAME PLATE,FRONT	A EA		2	*	*	*	*	*	*	*	*	6	8
X2 O 00011		SPACER: ENGINE MTG.ALUMINUM, 1 IN. W, 6 7/8 IN. LG. 1/4 IN. THK M617 (11568)	A EA		1									7	9
X2 O 00012		SPACER: ENGINE MTG,ALUMINUM, 1 IN. W, 6 7/8 IN. LG. 1/4 IN. THK M617 (11568)	F EA		2									7	9
O 00013	5310-087-7493	WASHER,FLAT: ENGINE MTG,BRACKET TO FRAME	AF EA		4	*	*	*	*	*	*	*	*	6	9
O 00014	5310-012-1753	WASHER,LOCK: ENGINE MTG,BRACKET TO ENGINE	AF EA		12	*	*	*	*	*	*	*	*	6	6

(1) SMR CODE INDEX NO.	(2) FEDERAL STOCK NUMBER	(3) DESCRIPTION REFERENCE NO. & MFR. CODE	(4) USABLE ON CODE UNIT OF ISSUE		(5) QTY INC IN UNIT PACK	(6) QTY INC IN UNIT	(7) 30-DAY DS MAINT ALLOWANCE (A) (B) (C)			(8) 30-DAY GS MAINT ALLOWANCE (A) (B) (C)			(9) 1-YR ALW PER 100 EQUIP CNTGNCY	(10) DEPOT MAINT ALW- PER 100 EQUIP	(11) ILLUS- TRATION (A) (B) FIG NO. ITEM NO.	
00015		0102 - CRANKSHAFT					1-20	21-50	51-100	1-20	21-50	51-100				
O 00016 O 00017 X2 O 00018	5315-043-1787 5310-762-6213 4310-828-8558	KEY,WOODRUFF: ENGINE CRANKSHAFT,DRIVE PULLEY MTG NUT,PLAIN,HEXAGON: ENGINE PULLEY SLEEVE,JAM PULLEY,GROOVE: ENGINE 2-1-2X1-1-2-2AL (11568)	AF AF A	EA EA EA	1 1 1		*	*	*	*	*	*	*	*	6	15
X2 O 00019		PULLEY,GROOVE: ENGINE 21-2X3-4ZVA (11568)	F	EA	1										6	14
X2 O 00020	4310-819-4222	SLEEVE,TAPER: ENGINE PULLEY M634 (11568)	AF	EA	1										6	13
00021		GROUP 03 - FUEL SYSTEM														
00022		0306 - TANKS,LINES,FITTINGS														
X2 O 00023		BOLT,U: FUEL TANK MTG, 1/4-20 THD SIZE, 6 IN. LG, 4 9/16 IN. W M607 (11568)	AF	EA	2										7	24
X2 O 00024		BRACKET: FUEL TANK MTG M606 (11568)	AF	EA	2										7	1
X2 O 00025		CLAMP,FUEL LINE: FUEL HOSE TO FRAME 5L19217 (11568)	F	EA	1											
X2 O 00026		CLAMP,HOSE: HOSE TO FUEL LINE 8R (72800)	F	EA	2											
O 00027	4730-221-3902	ELBOW,PIPE TO TUBE: FUEL LINE TO FILTER AND TANK	A	EA	2		*	*	*	*	*	*	*	*	7	25
M O 00028		HOSE,FUEL M694 (11568) MANUFACTURE FROM:	F	EA	1											
P O 00029 M O 00030	4720-807-8253	HOSE,FUEL (1 FT.REQUIRED) LINE ASSEMBLY: FUEL FILTER TO TANK MANUFACTURE FROM:	F A	FT EA	 1		*	*	*	*	*	*	5	5	7	26
O 00031	4730-142-1593	INVERTED NUT,TUBE COUPLING: FUEL LINE TO FILTER AND TANK ELBOWS	A	EA	2		*	*	*	*	*	*	*	*		

(1) SMR CODE INDEX NO.	(2) FEDERAL STOCK NUMBER	(3) DESCRIPTION	(4) USABLE ON CODE UNIT OF ISSUE	(5) QTY INC IN UNIT PACK	(6) QTY INC IN UNIT	(7) 30-DAY DS MAINT ALLOWANCE (A) (B) (C)	(8) 30-DAY GS MAINT ALLOWANCE (A) (B) (C)	(9) 1-YR ALW PER EQUIP CNTGNCY	(10) DEPOT MAINT ALW- PER EQUIP	(11) ILLUS- TRATION (A) (B) FIG NO. ITEM NO.
P O 00032 M O 00033	4710-277-5525	REFERENCE NO. & MFR. CODE TUBE,COPPER (3 FT.3 IN. REQUIRED)	A FT				SEE GRP 9501			
		LINE,FUEL M538A3 (11568) MANUFACTURE FROM:	F EA	1						
P O 00034 M O 00035	4710-277-5525	TUBE,COPPER (3 IN. REQUIRED)	F FT				SEE GRP 9501			
		LINE,FUEL M538A36 (11568) MANUFACTURE FROM:	F EA	1						
P O 00036 O 00037 X2 O 00038	4710-277-5525 4730-196-2054	TUBE,COPPER (36 IN. REQUIRED) NIPPLE,PIPE: ENGINE TO FILTER,FUEL LINE	F FT AF EA		1	* * *	* * *	* * *	* * *	
		NUT,SELF-LOCKING,HEXAGON: FUEL TANK MTG 29NE040 (72962)	AF EA	4						7 27
O 00039	4730-289-1959	NUT,TUBE COUPLING: FUEL TO FILTER AND TANK ELBOWS	F EA	2		* * *	* * *	* * *	* * *	
X2 O 00040		SCREW,SELF-TAPPING: FUEL LINE CLAMP ON FRAME N06X1-2 (87764)	F EA	1						
M O 00041		STRIP,ANTI-VIBRATION: FUEL TANK BRACKET, 3 IN. LG MANUFACTURE FROM:	A EA	2						7 2
P O 00042	8305-430-9284	WEBBING,TEXTILE (3 IN.REQUIRED FOR EACH STRIP)	A FT				SEE GRP 9501			
X2 O 00043		TANK ASSEMBLY,FUEL Z257 (11568)	AF EA	1						7 8
P O 00044	2910-705-7814	CAP AND CHAIN,FUEL TANK (CHAIN SOLDERED TO TANK) Z257-2 (11568)	AF EA	1		* * *	* * *	* * *	5 2	7 5
M O 00045	2910-992-6370	GASKET: FUEL TANK CAP Z257-3 (11568) MANUFACTURE FROM:	AF EA	1						7 4
P O 00046	5330-298-5674	CORK,SHEET (3 IN. X 3 IN. REQUIRED)	AF SH				SEE GRP 9501			

(1) SMR CODE INDEX NO.	(2) FEDERAL STOCK NUMBER	(3) DESCRIPTION REFERENCE NO. & MFR. CODE	(4) USABLE ON CODE UNIT OF ISSUE		(5) QTY INC IN UNIT PACK	(6) QTY INC IN UNIT	(7) 30-DAY DS MAINT ALLOWANCE (A) (B) (C)			(8) 30-DAY GS MAINT ALLOWANCE (A) (B) (C)			(9) 1-YR ALW PER 100 EQUIP CNTGNCY	(10) DEPOT MAINT ALW- PER 100 EQUIP	(11) ILLUS- TRATION (A) (B) FIG NO. ITEM NO.	
O 00047	4730-018-9566	PLUG,PIPE: FUEL TANK DRAIN	AF	EA	1		*	*	*	*	*	*	*	*	7	7
X2 O 00048		STRAINER ASSEMBLY: FUEL TANK Z257-4 (11568)	AF	EA	1										7	3
X1 00049		TANK,FUEL Z257-1 (11568)	AF	EA	1										7	6
X2 O 00050		WASHER: FUEL TANK MTG NUT 1-4W (79807)	AF	EA	4											
X2 O 00051		WASHER,LOCK: FUEL LINE TO FRAME CLAMP 6ETL (79807)	F	EA	1											
00052		GROUP 04 - EXHAUST SYSTEM														
00053		0401 - MUFFLER AND PIPES														
X2 O 00054		ADAPTER,MUFFLER M552 (11568)	A	EA	1										6	2
F O 00055	2990-269-7145	MUFFLER,EXHAUST 89966 (08645)	A	EA	1	*	2	2	*	2	2	20	20	6	3	
00056		GROUP 10 - FRONT AXLE														
00057		1000 - FRONT AXLE ASSEMBLY														
X2 O 00058		AXLE,HAND TRUCK Z261-9 (11568)	AF	EA	1										9	10
O 00059 00060	5315-811-6491	PIN,SPRING: AXLE	AF	EA	2	*	*	*	*	*	*	*	*	*	9	8
00061		GROUP 13 - WHEELS AND TRACKS														
00061		1311 - WHEEL ASSEMBLY														
O 00062	5315-839-5822	PIN,COTTER: COMPRESSOR HAND TRUCK WHEEL MTG	AF	EA	2	*	*	*	*	*	*	*	*	*	8	13
O 00063	5310-543-4488	WASHER,FLAT: COMPRESSOR HAND TRUCK WHEEL MTG	A	EA	2	*	*	*	*	*	*	*	*	*	8	12
X2 O 00064		WASHER,FLAT: WHEEL HUB SPACER, 21/32 IN. ID, 29/32 IN. OD, 0.095 IN. THK Z261-17 (11568)	A	EA	6										8	14

(1) SMR CODE INDEX NO.	(2) FEDERAL STOCK NUMBER	(3) DESCRIPTION	(4) USABLE ON CODE UNIT OF ISSUE	(5) QTY INC IN UNIT PACK	(6) QTY INC IN UNIT	(7) 30-DAY DS MAINT ALLOWANCE (A)	(7) 21-50 (B)	(7) 51-100 (C)	(8) 30-DAY GS MAINT ALLOWANCE (A)	(8) 21-50 (B)	(8) 51-100 (C)	(9) 1-YR ALW PER 100 EQUIP CNTGNCY	(10) DEPOT MAINT ALW- PER 100 EQUIP	(11) ILLUS- TRATION (A)	(11) (B)	FIG NO.	ITEM NO.
X2 O 00065		WHEEL ASSEMBLY: COMPRESSOR HAND TRUCK SD494 (11568)	A EA		2											8	
X1 00066		DISK: COMPRESSOR HAND TRUCK WHEEL, INNER B356-109 (11568)	A EA		2											8	9
X1 00067		DISK: COMPRESSOR HAND TRUCK WHEEL, OUTER B356-110 (11568)	A EA		2											8	6
X2 O 00068		HUB ASSEMBLY: COMPRESSOR HAND TRUCK WHEEL AW586 (11568)	A EA		2											8	4
X2 O 00069		BEARING, BALL: COMPRESSOR HAND TRUCK WHEEL HUB, 0.630 MIN, 0.634 MAX, ID BORE, UNGROUND B22-10 (11568)	A EA		4											8	3
X2 O 00070		BOLT, RIBBED SHOULDER: COMPRESSOR HAND TRUCK SIDE PLATES TO HUB MTG, 3/8-24 THD SIZE, 3/4 IN. LG AW533 (11568)	A EA		8											8	15
X2 O 00071		COVER, DUST: COMPRESSOR HAND TRUCK WHEEL HUB AW14-6 (11568)	A EA		4											8	1
O 00072	4730-365-0231	FITTING, LUBRICATION: COMPRESSOR HAND TRUCK WHEEL HUB	A EA		2	*	*	*	*	*	*	*	*	*			
M O 00073		WASHER, FELT: COMPRESSOR HAND TRUCK WHEEL HUB GREASE SEALS MANUFACTURE FROM:	A EA		4											8	2
P O 00074	8305-262-2543	FELT, STRIP (2 IN. X 2 IN. REQUIRED FOR EACH WASHER)	A FT						SEE	GRP	9501						
O 00075	5310-543-5653	NUT, PLAIN, HEXAGON: WHEEL SIDE PLATE BOLTS	A EA		20	*	*	*	*	*	*	*	*	*		8	11
O 00076	5305-638-8908	SCREW, CAP, HEXAGON HEAD: COMPRESSOR HAND TRUCK WHEEL SIDE PLATE SECURING	A EA		12	*	*	*	*	*	*	*	*	*		8	5
O 00077	5310-013-1099	WASHER, LOCK: COMPRESSOR HAND TRUCK WHEEL SIDE PLATES SECURING	A EA		20	*	*	*	*	*	*	*	*	*		8	10
X2 O 00078		WHEEL ASSEMBLY: HAND TRUCK A1560 (11431)	F EA		2											8	

(1) SMR CODE INDEX NO.	(2) FEDERAL STOCK NUMBER	(3) DESCRIPTION REFERENCE NO. & MFR. CODE	(4) USABLE ON CODE UNIT OF ISSUE		(5) QTY INC IN UNIT PACK	(6) QTY INC IN UNIT	(7) 30-DAY DS MAINT ALLOWANCE			(8) 30-DAY GS MAINT ALLOWANCE			(9) 1-YR ALW PER 100 EQUIP CNTGNCY	(10) DEPOT MAINT ALW- PER 100 EQUIP	(11) ILLUS- TRATION (A) (B) FIG NO. ITEM NO.	
			1-20	21-50	51-100	1-20	21-50	51-100	1-20	21-50	51-100					
X2 O 00079		BEARING 559 (11431)	F	EA		2									8	3
X2 O 00080		BOLT 306 (11431)	F	EA		6									8	15
X2 O 00081		COVER 4201 (11431)	F	EA		4									8	1
X1 00082		DISK 6460 (11431)	F	EA		2									8	9
X1 00083		DISK 6461 (11431)	F	EA		2									8	6
X2 O 00084		FLANGE 4219 (11431)	F	EA		2										
X2 O 00085		NUT 955 (11431)	F	EA		10									8	11
X2 O 00086		NUT 307 (11431)	F	EA		6									8	11
X2 O 00087		SCREW 954 (11431)	F	EA		10									8	5
X2 O 00088		TUBE 841 (11431)	F	EA		2										
X2 O 00089		WASHER 4216 (11431)	F	EA		4									8	12
M O 00090		WASHER 919 (11431)	F	EA		4									8	2
P O 00091	5330-262-2543	MANUFACTURE FROM: FELT STRIP (2 IN. BY 2 IN. REQUIRED FOR EACH SEAL)	F	FT					SEE	GRP	9501					
		1313 - TIRES,TUBES														
P O 00093	2610-051-9114	INNER TUBE,PNEUMATIC TIRE: COMPRESSOR HAND TRUCK WHEEL MS35392-48 (96906)	AF	EA		2	*	*	*	*	*	*	20	20	8	8

(1) SMR CODE INDEX NO.	(2) FEDERAL STOCK NUMBER	(3) DESCRIPTION	(4) USABLE ON CODE UNIT OF ISSUE	(5) QTY INC IN UNIT PACK	(6) QTY INC IN UNIT	(7) 30-DAY DS MAINT ALLOWANCE (A)	(7) 21-50 (B)	(7) 51-100 (C)	(8) 30-DAY GS MAINT ALLOWANCE (A)	(8) 21-50 (B)	(8) 51-100 (C)	(9) 1-YR ALW PER 100 EQUIP CNTGNCY	(10) DEPOT MAINT ALW- PER 100 EQUIP	(11) ILLUS- TRATION (A)	(11) (B)
		REFERENCE NO. & MFR. CODE				1-20	21-50	51-100	1-20	21-50	51-100				
P O 00094	2610-050-9560	TIRE,PNEUMATIC: COMPRESSOR HAND TRUCK WHEEL MS35389-1 (96906)	AF EA		2	*	*	*	*	*	*	20	20	8	7
00095		GROUP 15 - FRAME													
00096		1501 - FRAME ASSEMBLY													
X2 O 00097	4310-839-6555	HAND TRUCK ASSEM BLY: COMPRESSOR MTG P2249B (11568)	A EA		1									7	12
X2 O 00098		BUMPER, FRONT Z261-5 (11568)	A EA		1									9	6
X2 O 00099		BUMPER, REAR Z261-4 (11568)	A EA		1									9	3
X2 O 00100		FOOT,RUBBER: COMPRESSOR STAND Z261-18 (11568)	A EA		2									9	12
X2 O 00101		GUSSET: LEG Z261-20 (11568)	A EA		2									9	15
X2 O 00102		HANDLE,TURCH: RH AND LH Z261-3 (11568)	A EA		2									9	2
X2 O 00103		LEG,FRAME Z261-8 (11568)	A EA		1									9	13
X2 O 00104		MEMBER,CROSS: HAND TRUCK Z261-2 (11568)	A EA		5									9	17
X2 O 00105		NOSE,HAND TRUCK Z261-6 (11568)	A EA		1									9	7
X2 O 00106		NUT,SELF-LOCKING,HEXAGON: FRAME MTG,CADMIUM OR ZINC PLATED, 1/4-20 THD SIZE 29NE040 (72962)	A EA		28									9	5
X2 O 00107		RAIL,SIDE Z261-1 (11568)	A EA		2									9	4
X2 O 00108		SCREW,MACHINE: CROSS MEMBER MTG,CADMIUM OR ZINC PLATED, 1/4-20 THD SIZE, 1 3/4 IN. LG Z261-10 (11568)	A EA		10									9	18

(1) SMR CODE INDEX NO.	(2) FEDERAL STOCK NUMBER	(3) DESCRIPTION	(4) USABLE ON CODE UNIT OF ISSUE		(5) QTY INC IN UNIT PACK	(6) QTY INC IN UNIT	(7) 30-DAY DS MAINT ALLOWANCE			(8) 30-DAY GS MAINT ALLOWANCE			(9) 1-YR ALW PER 100 EQUIP CNTGNCY	(10) DEPOT MAINT ALW- PER 100 EQUIP	(11) ILLUS- TRATION (A) (B) FIG NO. ITEM NO.	
		REFERENCE NO. & MFR. CODE					1-20	21-50	51-100	1-20	21-50	51-100				
O 00109	5305-988-1725	SCREW,MACHINE: FOOT MTG	A	EA		2	*	*	*	*	*	*	*	*	9	11
O 00110	5305-988-1727	SCREW,MACHINE: LEG TO RAIL MTG	A	EA		4	*	*	*	*	*	*	*	*	19	14
O 00111 X2 O 00112	5305-988-1170	SCREW,MACHINE: NOSE AND HANDLE MTG	A	EA		12	*	*	*	*	*	*	*	*	9	9
X2 O 00113		SHIM,CROSS MEMBER Z261-7 (11568)	A	EA		10									9	16
X2 O 00113		TIP,HANDLE: COMPRESSOR FRAME HANDLES,RUBBER 1 1/8 IN. ID (CRUTCH TIP) Z261-19 (11568)	A	EA		2									9	1
X2 O 00114		HAND TRUCK ASSEMBLY: COMPRESSOR MTG Z261B (11568)	F	EA		1									7	12
X2 O 00115		BRACKET: ISOLATED MTG M657 (11568)	F	EA		1										
X2 O 00116		BUMPER,FRONT Z261-5A (11568)	F	EA		1									9	6
X2 O 00117		FOOT,RUBBER: ISOLATOR M651 (11568)	F	EA		2									9	12
X2 O 00118		GUSSET: LEG Z261-20 (11568)	F	EA		2									9	15
X2 O 00119		HANDLE,TRUCK: RH AND LH Z261-3 (11568)	F	EA		2									9	2
X2 O 00120		LEG,FRAME Z261-8 (11568)	F	EA		1									9	13
X2 O 00121		MEMBER,CROSS Z261-2A (11568)	F	EA		6									9	17
X2 O 00122		NOSE,HAND TRUCK Z261-6A (11568)	F	EA		1									9	7
X2 O 00123		NUT,LOCK Z261-13 (11568)	F	EA		31									9	5
X2 O 00124		NUT,SELF-LOCKING 29NE040 (72962)	F	EA		2									9	5

(1) SMR CODE INDEX NO.	(2) FEDERAL STOCK NUMBER	(3) DESCRIPTION REFERENCE NO. & MFR. CODE	(4) USABLE ON CODE UNIT OF ISSUE	(5) QTY INC IN UNIT PACK	(6) QTY INC IN UNIT	(7) 30-DAY DS MAINT ALLOWANCE (A)	(7) 21-50 (B)	(7) 51-100 (C)	(8) 30-DAY GS MAINT ALLOWANCE (A)	(8) 21-50 (B)	(8) 51-100 (C)	(9) 1-YR ALW PER 100 EQUIP CNTGNCY	(10) DEPOT MAINT ALW- PER 100 EQUIP	(11) ILLUS- TRATION (A)	(11) (B)	FIG NO.	ITEM NO.
X2 O 00125		NUT,SELF-LOCKING 29NE058 (72962)	F EA		2											9	5
X2 O 00126		RAIL,SIDE Z261-1A (11568)	F EA		2											9	4
O 00127	5305-649-8115	SCREW,CAP,HEXAGON HEAD	F EA		2	*	*	*	*	*	*	*	*				
X2 O 00128		SCREW,MACHINE: CROSS MEMBER MTG Z261-10 (11568)	F EA		12											9	18
O 00129	5305-988-1725	SCREW,MACHINE: RUBBER ISOLATOR MTG	F EA		2	*	*	*	*	*	*	*	*			9	11
O 00130	5305-558-2679	SCREW,MACHINE: LEG TO RAIL MTG	F EA		8	*	*	*	*	*	*	*	*			9	14
X2 O 00131		SCREW,MACHINE: NOSE AND HANDLE MTG, 1/4-20 THD SIZE, 1 1/2 IN. LG X261-15 (11568)	F EA		8											9	9
X2 O 00132		TIP,HANDLE: FRAME HANDLES Z261-19 (11568)	F EA		2											9	1
X2 O 00133	2920-064-8834	STRAP,GROUND: ENGINE TO FRAME M640 (11568)	AF EA		1											6	4
X2 O 00134		WASHER Z261-17 (11568)	F EA		4												
00135		GROUP 22 - BODY CHASSIS AND HULL,AND ACCESSORY ITEMS															
00136		2202 - ACCESSORY ITEMS															
X2 O 00137	4310-887-8765	CHUCK,AIR: TIRE INFLATING 699 (94894)	A EA		1											14	11
P O 00138	4910-204-2644	GAGE,AIR: TIRE INFLATING 7300CTDRC (08070)	DF EA		1	*	*	*	*	*	*	5	5			15	6
X2 O 00139		GAGE,INFLATION 730DCTDRG (08070)	E EA		1											15	6
X2 O 00140		GAGE,INFLATOR G1506 (94894)	B EA		1											15	6

(1) SMR CODE INDEX NO.	(2) FEDERAL STOCK NUMBER	(3) DESCRIPTION	(4) USABLE ON CODE UNIT OF ISSUE	(5) QTY INC IN UNIT PACK	(6) QTY INC IN UNIT	(7) 30-DAY DS MAINT ALLOWANCE (A)	(7) 30-DAY DS MAINT ALLOWANCE (B)	(7) 30-DAY DS MAINT ALLOWANCE (C)	(8) 30-DAY GS MAINT ALLOWANCE (A)	(8) 30-DAY GS MAINT ALLOWANCE (B)	(8) 30-DAY GS MAINT ALLOWANCE (C)	(9) 1-YR ALW PER 100 EQUIP CNTGNCY	(10) DEPOT MAINT ALW- PER 100 EQUIP	(11) ILLUS- TRATION (A)	(11) ILLUS- TRATION (B)
X2 O 00141		REFERENCE NO. & MFR. CODE GGE, INFLATOR 730DCTDRC (08070)	C EA		1									15	6
P O 00142	4310-874-3179	HOSE ASSEMBLY, AIR Z538A (11568)	BCE EA		1	2	2	3	2	2	3	30	20	15	7
P O 00143	4310-874-3179	HOSE ASSEMBLY, RUBBER F538A (11568)	D EA		1	*	2	2	*	2	2	15	10	15	7
P O 00144	4310-873-1767	HOSE ASSEMBLY, RUBBER: AIR, 5/16 IN. ID Z538 (11568)	AF EA		1	*	2	2	*	2	2	15	10	14	12
		2210 - DATA PLATES AND INSTRUCTION HOLDERS													
X2 O 00146		DIAGRAM, WIRING WD9920W (21810)	CDE EA		1										
X2 O 00147		PLATE, IDENTIFICATION: COMPRESSOR PMSM (11568)	ABCF EA		1									1	11
X2 O 00148		PLATE, IDENTIFICATION: COMPRESSOR M645 (11568)	DE EA		1									1	11
X2 F 00149	9905-807-3712	PLATE, IDENTIFICATION: CORPS OF ENGINEERS, TYPE A	EA		1									7	11
X2 O 00150		PLATE, IDENTIFICATION: MAGNETIC STARTER Y9389X (21810)	BCDE EA		1									13	24
F 00151	5305-012-1279	SCREW, DRIVE: CORPS OF ENGINEERS PLATE MTG	EA		4	*	*	*	*	*	*	*	*	7	10
O 00152	5305-253-5612	SCREW, DRIVE: IDENTIFICATION PLATE MTG	ABCF EA		2	*	*	*	*	*	*	*	*	1	10
O 00153	5305-012-1279	SCREW, DRIVE: IDENTIFICATION PLATE MTG	DE EA		6	*	*	*	*	*	*	*	*	1	10
O 00154	5305-993-0184	SCREW, MACHINE: MAGNETIC STARTER IDENTIFICATION PLATE MTG	BCDE EA		1	*	*	*	*	*	*	*	*	13	23

(1) SMR CODE INDEX NO.	(2) FEDERAL STOCK NUMBER	(3) DESCRIPTION	(4) USABLE ON CODE UNIT OF ISSUE	(5) QTY INC IN UNIT PACK	(6) QTY INC IN UNIT	(7) 30-DAY DS MAINT ALLOWANCE (A)	(8) 30-DAY GS MAINT ALLOWANCE (B)	(9) 1-YR ALW PER EQUIP CNTGNCY	(10) DEPOT MAINT ALW- PER EQUIP	(11) ILLUS- TRATION (A)	(11) ITEM NO.				
00155		GROUP 40 - ELECTRIC MOTORS AND GENERATORS (OTHER THAN ENGINE ACCESSORIES)				1-20	21-50	51-100	1-20	21-50	51-100				
00156		4000 - MOTOR ASSEMBLIES													
P O R 00157	6105-887-4469	MOTOR,ALTERNATING CURRENT: 2 HP, 115/230 V 184CSR29BBCW (38151) (ELECTRIC MOTORS AND REPAIR PARTS ARE TO BE REQUISITIONED BY COMPLETE IDENTIFYING NOMEN- CLATURE. COMPLETE MOTOR AND FRAME NAMEPLATE DATA MUST BE SHOWN ON THE REQUISITION TO INSURE SUPPLY OF THE PROPER REPAIR PARTS OR MOTOR)	C	EA	1	*	*	*	*	*	*	5	3	11	7
P O R 00158	6105-877-2629	MOTOR,ELECTRIC: 2 HP 184TSR27BB (38151) (ELECTRIC MOTORS AND REPAIR PARTS ARE TO BE REQUISITIONED BY COMPLETE IDENTIFYING NOMEN- CLATURE. COMPLETE MOTOR AND FRAME NAMEPLATE DATA MUST BE SHOWN ON THE REQUISITION TO INSURE SUPPLY OF THE PROPER REPAIR PARTS OR MOTOR)	BD	EA	1	*	*	*	*	*	*	3	3	11	7
X2OR 00159		MOTOR,ELECTRIC 184P4R2158 (38151) (ELECTRIC MOTORS AND REPAIR PARTS ARE TO BE REQUISITIONED BY COMPLETE IDENTIFYING NOMEN- CLATURE. COMPLETE MOTOR AND FRAME NAMEPLATE DATA MUST BE SHOWN ON THE REQUISITION TO INSURE SUPPLY OF THE PROPER REPAIR PARTS OR MOTOR)	E	EA	1									11	7
O 00160	5310-732-0558	NUT,PLAIN,HEXAGON: MOTOR TO RECEIVER BRACKET MTG	BCE	EA	4	*	*	*	*	*	*	*	*	11	6
X2 O 00161	5310-010-2635	NUT,PLAIN,HEXAGON: MOTOR TO RECEIVER MTG 3-8N (87764)		EA	4									11	6
X2 O 00162	5305-060-6800	SCREW,CAP,HEXAGON HEAD: MOTOR TO RECEIVER MTG 3-8-16X1-1-4CS (87764)		EA	4									11	3
X2 O 00163	5305-010-0135	SCREW,CAP,HEXAGON HEAD: MOTOR TO RECEIVER PLATFORM MTG M456 (11568)	E	EA	4									11	3
O 00164	5305-021-4389	SCREW,CAP,HEXAGON HEAD: MOTOR TO RECEIVER PLATFORM MTG	C	EA	4	*	*	*	*	*	*	*	*	11	3

(1) SMR CODE INDEX NO.	(2) FEDERAL STOCK NUMBER	(3) DESCRIPTION	(4) USABLE ON CODE UNIT OF ISSUE		(5) QTY INC IN UNIT PACK	(6) QTY INC IN UNIT	(7) 30-DAY DS MAINT ALLOWANCE			(8) 30-DAY GS MAINT ALLOWANCE			(9) 1-YR ALW PER 100 EQUIP CNTGNCY	(10) 1-YR DEPOT MAINT ALW- PER 100 EQUIP	(11) ILLUS- TRATION (A) (B)	
		REFERENCE NO. & MFR. CODE					1-20	21-50	51-100	1-20	21-50	51-100		FIG NO.	ITEM NO.	
X2 O 00165		SCREW,CAP,HEXAGON HEAD: MOTOR TO RECEIVER PLATFORM MTG,CADMIUM OR ZINC PLATED, 3/8-16 THD SIZE, 1 IN. LG E1531-62R (38151)	B	EA		4								11	3	
X2 O 00166	5310-050-2234	WASHER,FLAT: MOTOR TO RECEIVER MTG 3-8FN (79807)	DE	EA		4								11	4	
O 00167	5310-087-7493	WASHER,FLAT: MOTOR TO RECEIVER PLATFORM MTG	BC	EA		4	*	*	*	*	*	*	*	11	4	
X2 O 00168		WASHER,LOCK: MOTOR TO RECEIVER MTG MS35338-8 (96906)	D	EA		4								11	5	
X2 O 00169	5310-582-3341	WASHER,LOCK: MOTOR TO RECEIVER PLATFORM MTG 3-8LW(11568)	E	EA		4								11	5	
O 00170 00171	5310-637-9541	WASHER,LOCK: MOTOR TO RECEIVER PLATFORM MTG 4001 - ROTOR ASSEMBLIES	BC	EA		4	*	*	*	*	*	*	*	11	5	
X2 F 00172	6105-887-4467	ROTOR ASSEMBLY: MOTOR AH84E40C10 (38151)	CD	EA		1								12	8	
X2 F 00173	6105-887-8681	ROTOR ASSEMBLY: MOTOR AC84F25G23 (38151)	B	EA		1								12	8	
X1 00174		SHAFT,ROTOR A61510-675 (38151)	B	EA		1								12	7	
X2 F 00175		ROTOR ASSEMBLY: MOTOR AAF84E22G (38151)	E	EA		1								12	8	
X1 00176		SHAFT,ROTOR A61510-675 (38151)	E	EA		1								12	7	
X2 F 00177		SHAFT,ROTOR A61655-775 (38151)	CD	EA		1								12	7	
00178		4002 - STATOR ASSEMBLIES														
X2 H 00179		FRAME AND STATOR: MOTOR AAC61406-66 (38151) (COMPONENT OF MOTOR, STOCK NO. 6105-877-2629)	B	EA		1								12	14	

(1) SMR CODE INDEX NO.	(2) FEDERAL STOCK NUMBER	(3) DESCRIPTION	(4) USABLE ON CODE UNIT OF ISSUE		(5) QTY INC IN UNIT PACK	(6) QTY INC IN UNIT	(7) 30-DAY DS MAINT ALLOWANCE			(8) 30-DAY GS MAINT ALLOWANCE			(9) 1-YR ALW PER 100 EQUIP CNTGNCY	(10) 1-YR DEPOT MAINT ALW- PER 100 EQUIP	(11) ILLUS- TRATION (A) (B)	
		REFERENCE NO. & MFR. CODE					1-20	21-50	51-100	1-20	21-50	51-100		FIG NO.	ITEM NO.	
X2 F 00180		FRAME AND STATOR: MOTOR EAC263298-5 (38151)	D	EA		1								12	14	
X2 H 00181		FRAME AND STATOR: MOTOR EAC63298-5 (38151)	C	EA		1								12	14	
X1 00182		FRAME AND STATOR AAC6276246 (38151) (COMPONENT OF MOTOR, STOCK NO. (38151) 184P4R2158)	E	EA		1								12	14	
00183		4004 - VENTILATING SYSTEM														
X2 H 00184		BAFFLE, MOTOR E60146-2C (38151)	B	EA		1								12	13	
X2 F 00185		BAFFLE, MOTOR E60766-2 (38151)	E	EA		1								12	3	
X2 H 00186		BAFFLE, MOTOR E60766C (38151)	B	EA		1								12	3	
X2 F 00187		BAFFLE, MOTOR E60146-3 (38151)	E	EA		1								12	13	
X2 F 00188		BAFFLE, MOTOR EA60146C1C (38151)	CD	EA		1								12	13	
X2 F 00189		BAFFLE, MOTOR E61477AC (38151)	CD	EA		1								12	3	
X2 F 00190	6150-894-1010	FAN, MOTOR: VENTILATING A61437DA (38151)	B	EA		1								12	6	
X2 F 00191		FAN, MOTOR: VENTILATING EA71974B (38151)	E	EA		1								12	6	
X2 F 00192		SETScrew: MOTOR VENTILATING FAN, CADMIUM OR ZINC PLATED, NO. 10-32 THD SIZE, 3/16 IN. LG		EA		2								12	19	
00193		4005 - FRAME SUPPORTS AND HOUSINGS														
X2 F 00194		BASE, FOB CONNECTOR A61212C (38151)	BCD	EA		1								12	18	

(1) SMR CODE INDEX NO.	(2) FEDERAL STOCK NUMBER	(3) DESCRIPTION	(4)			(5) QTY INC IN UNIT PACK	(6) QTY INC IN UNIT	(7) 30-DAY DS MAINT ALLOWANCE			(8) 30-DAY GS MAINT ALLOWANCE			(9) 1-YR ALW PER 100 EQUIP CNTGNCY	(10) DEPOT MAINT ALW- PER 100 EQUIP	(11) ILLUS- TRATION (A) (B)	
		REFERENCE NO. & MFR. CODE	USABLE ON CODE	UNIT OF	ISSUE		1-20	21-50	51-100	1-20	21-50	51-100		FIG NO.	ITEM NO.		
X2 F 00195		BASE,BOX CONNECTOR A61212-3 (38151)	E	EA		1									12	18	
P F 00196	3110-144-8648	BEARING,BALL,ANNULAR: MOTOR SHAFT,BRACKET E7848-35 (83151)	D	EA		1	*	*	2	*	*	2	10	10	12	16	
P F 00197	3110-144-8622	BEARING,BALL,ANNULAR: MOTOR SHAFT,BRACKET 77505 (43334)	BE	EA		1	*	*	2	*	*	2	10	10	12	16	
P F 00198	3110-144-8589	BEARING,BALL,ANNULAR: MOTOR SHAFT,BRACKET END 77503 (43334)	CE	EA		1	*	*	2	*	*	2	10	10	12	16	
P F 00199	3110-144-8589	BEARING,BALL,ANNULAR: MOTOR SHAFT DRIVE END E7848-17 (83151)	D	EA		1	*	*	2	*	*	2	10	10	12	4	
P F 00200	3110-144-8589	BEARING,BALL,ANNULAR: MOTOR SHAFT DRIVE END 77503 (43334)	B	EA		1	*	*	2	*	*	2	10	10	12	4	
P F 00201	3110-144-8648	BEARING,BALL,ANNULAR: MOTOR SHAFT,DRIVE END 77507 (43334)	C	EA		1	*	*	2	*	*	2	10	10	12	4	
X2 F 00202		BOLT,STUD: MOTOR A60128-22S (38151)	D	EA		4									12	5	
X2 F 00203		BOLT,STUD: MOTOR,CADMIUM OR ZINC PLATED, 1/4-20 THD SIZE,BOTH ENDS, 9 5/8 IN. LG A60128-42S (38151)	BE	EA		4									12	5	
M F 00204		BOLT,STUD: MOTOR THRU BOLT A60128-22R (38151) MANUFACTURE FROM:	C	EA		4									12	5	
P F 00205	9510-229-0883	BAR,STEEL	C	FT						SEE	GRP	9501					
X2 F 00206		BRACKET,FRONT: MOTOR AA61485D (38151)	E	EA		1									12	2	
X2 F 00207		BRACKET,MOTOR: BEARING END AA61240AC (38151)	B	EA		1									12	11	
X2 F 00208		BRACKET,MOTOR: BEARING END AA62941AC (38151)	CD	EA		1									12	11	

(1) SMR CODE INDEX NO.	(2) FEDERAL STOCK NUMBER	(3) DESCRIPTION REFERENCE NO. & MFR. CODE	(4) USABLE ON CODE UNIT OF ISSUE	(5) QTY INC IN UNIT PACK	(6) QTY INC IN UNIT	(7) 30-DAY DS MAINT ALLOWANCE (A)	(8) 30-DAY GS MAINT ALLOWANCE (B)	(9) 1-YR ALW PER EQUIP CNTG	(10) DEPOT MAINT ALW- PER EQUIP	(11) ILLUS- TRATION (A) (B)	FIG NO.	ITEM NO.
X2 F 00209		BRACKET,MOTOR: DRIVE END AA62931AC (38151)	B EA		1						12	2
X2 F 00210		BRACKET,MOTOR: DRIVE END AA61475DC (38151)	CD EA		1						12	
X2 F 00211		BRACKET,REAR: MOTOR HA61551A (38151)	E EA		1						12	11
X2 O 00212	5340-664-0403	BUTTON,PLUG: BRACKET SHAFT END,NICKEL PLATED, 1 IN. 12 PRONG	BC EA		1						12	10
X2 F 00213	5310-268-6154	NUT,PLAIN,HEXAGON: MOTOR STUD,CADMIUM OR ZINC PLATED, 1/4-20 THD SIZE E7551-9R (38151)	BCDE EA		8						12	1
X2 O 00214		PLUG,DRAIN E7497-3 (38151)	E EA		1						12	12
X2 O 00215		PLUG,GREASE E4850-6 (38151)	E EA		2						12	9
X2 O 00216	4730-044-4697	PLUG,PIPE: DRAIN E7497-1 (38151)	EA		2						12	12
O 00217	4730-278-3395	PLUG,PIPE: DRAIN	B EA		2	*	*	*	*	*	12	12
O 00218	4730-278-3425	PLUG,PIPE: DRAIN	C EA		2	*	*	*	*	*	12	12
O 00219	4730-278-3397	PLUG,PIPE: GREASE,BRASS, 1/8-27 THD SIZE	BD EA		2	*	*	*	*	*	12	9
O 00220	4730-011-8831	PLUG,PIPE: GREASE	C EA		2	*	*	*	*	*	12	9
X2 O 00221		SCREW: BASE BOX CONNECTOR MTG E7531-62 (38151)	E EA		4						12	17
O 00222	5305-021-5450	SCREW,CAP,HEXAGON HEAD: BOX CONNECTOR BASE TO MOTOR	C EA		4	*	*	*	*	*	12	17
X2 O 00223		SCREW: FRONT BRACKET E7531-162 (38151)	E EA		4							

(1) SMR CODE INDEX NO.	(2) FEDERAL STOCK NUMBER	(3) DESCRIPTION	(4) USABLE ON CODE UNIT OF ISSUE	(5) QTY INC IN UNIT PACK	(6) QTY INC IN UNIT	(7) 30-DAY DS MAINT ALLOWANCE (A)	(7) 30-DAY DS MAINT ALLOWANCE (B)	(7) 30-DAY DS MAINT ALLOWANCE (C)	(8) 30-DAY GS MAINT ALLOWANCE (A)	(8) 30-DAY GS MAINT ALLOWANCE (B)	(8) 30-DAY GS MAINT ALLOWANCE (C)	(9) 1-YR ALW PER 100 EQUIP CNTGCTY	(10) DEPOT MAINT ALW- PER 100 EQUIP	(11) ILLUS- TRATION (A)	(11) ITEM NO. (B)
		REFERENCE NO. & MFR. CODE				1-20	21-50	51-100	1-20	21-50	51-100				
X2 O 00224	5305-012-0583	SCREW,MACHINE: BASE TO MOTOR MTG	D EA		4									12	17
O 00225	5305-012-0583	SCREW,MACHINE: BASE TO MOTOR MTG	B EA		2	*	*	*	*	*	*	*	*	12	17
F 00226	5310-887-4598	WASHER,SPRING TENSION	BCDE EA		1	*	*	*	*	*	*	*	*	12	15
00227		4006 - STARTING DEVICES													
F F 00228	5910-887-4654	CAPACITOR: MOTOR, 115 VAC A4488-650 (38151)	CD EA		1	*	*	2	*	*	2	10	10		
X2 F 00229	6110-887-4468	CONTACT,ELECTRICAL AS61046-5 (38151)	D EA		1										
X2 F 00230		HOUSING,CAPACITOR A61351C (38151)	CD EA		1										
F 00231	5305-285-4531	SCREW,MACHINE: CAPACITOR HOUSING MTG	C EA		2	*	*	*	*	*	*	*	*		
X2 F 00232		SWITCH,STARTING AS61061-5 (38151)	D EA		1										
00233		4007 - DRIVE COMPONENTS													
X2 O 00234		KEY U8 (11568)	E EA		1									11	8
O 00235	5315-057-6607	KEY,MACHINE: MOTOR SHAFT	BCD EA		1	*	*	*	*	*	*	*	*	11	8
X2 O 00236	3020-837-1270	PULLEY,MOTOR M498 (11568)	BCE EA		1									11	2
X2 O 00237		PULLEY,MOTOR 5-1-4X7-82VA (11568)	D EA		1									11	2
O 00238	5305-724-6810	SETSCREW: MOTOR PULLEY	BCE EA		1	*	*	*	*	*	*	*	*	11	9
X2 O 00239	5305-013-9412	SETSCREW: PULLEY MTG 3-8-16X3-8SS (11568)	D EA		1									11	9
00240		4010 - MASTER OR AUXILIARY CONTROL ASSEMBLY													
O 00241	4730-288-9930	ADAPTER,STRAIGHT,PIPE TO TUBE: AIR PRESSURE SWITCH TO AIR RECEIVER LINE	BCD EA		1	*	*	*	*	*	*	*	*	13	18

(1) SMR CODE INDEX NO.	(2) FEDERAL STOCK NUMBER	(3) DESCRIPTION REFERENCE NO. & MFR. CODE	(4) USABLE ON CODE UNIT OF ISSUE	(5) QTY INC IN UNIT PACK	(6) QTY INC IN UNIT	(7) 30-DAY DS MAINT ALLOWANCE (A) (B) (C)	(8) 30-DAY GS MAINT ALLOWANCE (A) (B) (C)	(9) 1-YR ALW PER 100 EQUIP CNTGNCY	(10) DEPOT MAINT ALW- PER 100 EQUIP	(11) ILLUS- TRATION (A) (B) FIG NO. ITEM NO.
X2 O 00242		ELBOW,PIPE TO TUBE: AIR PRESSURE SWITCH TO AIR RECEIVER LINE,BRASS, ONE END MALE, 1/8-27 THD SIZE,OTHER END FEMALE, 1/4 IN. TUBE,7/16-24 THD SIZE 189D1-4X1-8 (30327)	B EA		1	1-20 21-50 51-100	1-20 21-50 51-100			13 16
O 00243	4730-277-8276	ELBOW,PIPE TO TUBE: AIR RECEIVER TO AIR PRESSURE SWITCH LINE	BC EA		1	* * *	* * *	* * *	* * *	13 16
P O 00244	4310-877-2625	HEATER,OVERLOAD: MAGNETIC STARTER, 416 V F7-1-416V (21810)	B EA		2	2 2 3	2 2 3	30	20	
P O 00245	6110-887-4466	HEATER,OVERLOAD: 230 V F14-2-230V (21810)	C EA		1	* * 2	* * 2	10	10	
P O 00246	6110-532-7789	HEATER,THERMAL RELEASE: 115 V F28-0-115V (21810)	C EA		1	* * 2	* * 2	10	10	
M O 00247		LEAD,ELECTRICAL: CONTROL,PRESSURE SWITCH TO 1H OVERLOAD RELAY MANUFACTURE FROM:	B EA		1					13 7
X2 O 00248	5940-681-9713	TERMINAL,LUG: COPPER,TINNED FINISH,NO. 16 TO NO. 14 AWG,FOR NO. 10 SCREW SIZE	B EA		2					
P O 00249	6145-542-6039	WIRE,ELECTRICAL (8 IN. REQUIRED)	B FT				SEE GRP	9501		
P O 00250	5930-521-8471	REPAIR KIT,PRESSURE SWITCH PK55 (23826)	BC EA		1	2 4 8	2 4 8	100	100	
X1 00251		CONTACT SET D9805 (23826)	BC EA		1					
X1 00252		DIAPHRAGM,AIR D274-1 (23826)	BC EA		1					
X1 00253		PIN,PUSH ROD D354-1 (23826)	BC EA		2					
X1 00254		ROD,PUSH D334-1(23826)	BC EA		2					
X1 00255		SCREW,MACHINE: CONTACT MTG,NO. 8-32 THD SIZE, 3/8 IN. LG S108 (23826)	BC EA		4					

(1) SMR CODE INDEX NO.	(2) FEDERAL STOCK NUMBER	(3) DESCRIPTION REFERENCE NO. & MFR. CODE	(4) USABLE ON CODE UNIT OF ISSUE	(5) QTY INC IN UNIT PACK	(6) QTY INC IN UNIT	(7) 30-DAY DS MAINT ALLOWANCE (A)	(8) 30-DAY GS MAINT ALLOWANCE (A)	(9) 1-YR ALW PER EQUIP CNTG	(10) DEPOT MAINT ALW- PER EQUIP	(11) ILLUS- TRATION (A)	(B) (B) ITEM NO.				
X1 00256		SPRING, CONTACT D358-1 (23826)	BC EA		2										
X2 O 00257	5305-558-3679	SCREW, MACHINE: MAGNETIC STARTER BOX AND PLATE MTG, CADMIUM OR ZINC PLATED, 1/4-20 THD SIZE, 1 IN. LG	C EA		2										
X2 O 00258		STARTER, MAGNETIC 4204AA13J201-51 (21810)	B EA		1					13					
X2 O 00259		BOX, STARTER A9913Y (21810)	B EA		1					13	14				
P O 00260	6110-887-2623	COIL, MAGNETIC STARTER ACA151 (21810)	B EA		1	*	*	*	*	*	5	5	13	20	
P O 00261	6110-887-2626	CONTACT ASSEMBLY, ELECTRICAL: MOVABLE L6248W2 (21810)	B EA		1	*	2	2	*	2	2	15	15	13	10
P O 00262	6110-887-2627	CONTACT, ELECTRICAL: STATIONARY LINE L6289L2 (21810)	B EA		3	2	2	3	2	2	3	30	30	13	12
P O 00263	6110-883-4227	CONTACT, ELECTRICAL, STATIONARY LOAD L6290L2 (21810)	B EA		3	2	2	3	2	2	3	30	30	13	11
X2 O 00264		COVER, STARTER A9917X (21810)	B EA		1									13	8
P O 00265	6110-757-1758	HEATER, OVERLOAD: MAGNETIC STARTER, 208 V F12-6-208V (21810)	B EA		2	*	2	2	*	2	2	20	20	13	6
M O 00266		LEAD, ELECTRICAL: CONTROL, PRESSURE SWITCH TO MAGNETIC SWITCH 14TW80CSTR (21810) MANUFACTURE FROM:	B EA		1									13	1
X2 O 00267	5940-681-9713	TERMINAL, LUG: COPPER, TINNED FINISH, NO. 16-14 AWG, FOR NO. 10 SCREW SIZE	B EA		2										
P O 00268	6145-542-6039	WIRE, ELECTRICAL (12 IN. REQUIRED)	B FT					SEE	GRP	9501					

(1) SMR CODE INDEX NO.	(2) FEDERAL STOCK NUMBER	(3) DESCRIPTION REFERENCE NO. & MFR. CODE	(4) USABLE ON CODE UNIT OF ISSUE	(5) QTY INC IN UNIT PACK	(6) QTY INC IN UNIT	(7) 30-DAY DS MAINT ALLOWANCE (A) (B) (C)	(8) 30-DAY GS MAINT ALLOWANCE (A) (B) (C)	(9) 1-YR ALW PER 100 EQUIP CNTGNCY	(10) DEPOT MAINT ALW- PER 100 EQUIP	(11) ILLUS- TRATION (A) (B) FIG NO. ITEM NO.
M O 00269		LEAD,ELECTRICAL: MAGNETIC,SWITCH TO LH OVERLOAD RELAY,AND RH TO LH OVERLOAD RELAY MANUFACTURE FROM:	B EA		2					13 9
P O 00270	6145-161-5415	WIRE,ELECTRICAL (12 IN. REQUIRED FOR EACH LEAD)	B FT				SEE GRP 9501			
M O 00271		LEAD,ELECTRICAL: POWER,MAGNETIC SWITCH TO RH AND LH OVERLOAD RELAY 10TW90DEGCS0L (21810) MANUFACTURE FROM:	B EA		2					13 5
P O 00272	6145-191-2575	WIRE,ELECTRICAL (5 IN. REQUIRED FOR EACH LEAD)	B FT				SEE GRP 9501			
X2 O 00273	5975-152-1075	LOCKNUT,ELECTRICAL CONDUIT: PRESSURE SWITCH TO MAGNETIC STARTER SWITCH BOX,GLAVANIZED, 1/2-14 THD SIZE	B EA		1					13 19
X2 O 00274		MAGNET,MOVABLE L7030W2 (21810)	B EA		1					13 3
X2 O 00275		MAGNET,STATIONARY L7030W1 (21810)	B EA		1					13 27
X2 O 00276		PLATE,IDENTIFICATION: MAGNETIC STARTER Y9389X (21810)	B EA		1		SEE GRP 2210			
X2 O 00277		PLATE,LOCK: MOVABLE MAGNET RETAINER C6247V (21810)	B EA		1					13 22
X2 O 00278		PLATE,MOTOR MOUNTING C9906W (21810)	B EA		1					13 15
X2 O 00279	5945-020-6725	RELAY,OVERLOAD: LH L8833L3 (21810)	B EA		1					13 21
X2 O 00280	5945-020-6726	RELAY,OVERLOAD: RH L8833L4 (21810)	B EA		1					13 13
X2 O 00281	5305-933-0184	SCREW,MACHINE: MAGNETIC STARTER IDENTIFICATION PLATE MTG	B EA		1		SEE GRP 2210			

(1) SMR CODE INDEX NO.	(2) FEDERAL STOCK NUMBER	(3) DESCRIPTION	(4) USABLE ON CODE UNIT OF ISSUE	(5) QTY INC IN UNIT PACK	(6) QTY INC IN UNIT	(7) 30-DAY DS MAINT ALLOWANCE (A)	(7) 21-50 (B)	(7) 51-100 (C)	(8) 30-DAY GS MAINT ALLOWANCE (A)	(8) 21-50 (B)	(8) 51-100 (C)	(9) 1-YR ALW PER 100 EQUIP CNTGNCY	(10) DEPOT MAINT ALW- PER 100 EQUIP	(11) ILLUS- TRATION (A)	(11) (B) FIG NO.	(11) ITEM NO.
P O 00282	5340-766-0331	REFERENCE NO. & MFR. CODE SPRING,HELICAL,COMPRESSION: COIL RETAINER 7224874 (21810)	B EA	1		*	*	*	*	*	*	5	5	13	4	
X2 O 00283	5930-430-4071	SWITCH,PRESSURE: MAGNETIC SWITCH H1 (23826)	B EA	1										13	2	
X2 O 00284	6110-887-4551	STARTER,MAGNETIC 4204AA12J201-26 (21810)	C EA	1										13		
X2 O 00285		BOX,STARTER A9913Y (21810)	C EA	1										13	14	
P O 00286	5950-532-7843	COIL,RELAY ACA126 (21810)	C EA	1		*	*	*	*	*	*	5	5	13	20	
P O 00287	6110-877-2627	CONTACT,ELECTRICAL: STATIONARY LINE L6289L2 (21810)	C EA	2		*	2	2	*	2	2	20	20	13	12	
P O 00288	6110-883-4227	CONTACT,ELECTRICAL: STATIONARY LOAD L6290L2 (21810)	C EA	2		*	2	2	*	2	2	20	20	13	11	
P O 00289	6110-877-2626	CONTACT ASSEMBLY,ELECTRICAL: MOVABLE L6248W2 (21810)	C EA	2		*	2	2	*	2	2	20	20	13	10	
X2 O 00290		COVER,STARTER A9917X (21810)	C EA	1										13	8	
X2 O 00291		DIAGRAM,WIRING WD9920W (21810)	C EA	1					SEE	GRP	2210					
M O 00292		LEAD,ELECTRICAL: CONTRACTOR TO OVERLOAD HEATER MANUFACTURE FROM:	C EA	1												
P O 00293	6145-295-1309	WIRE,ELECTRICAL (5 IN. REQUIRED)	C FT						SEE	GRP	9501					
M O 00294		LEAD,ELECTRICAL: MAGNETIC STARTER TO CONTACTOR TERMINAL MANUFACTURE FROM:	C EA	1												
X2 O 00295	5940-050-6207	TERMINAL,LUG: COPPER,TINNED FINISH,NO. 16-24 AWG,FOR NO. 8 SCREW SIZE	C EA	2												
P O 00296	6145-160-5137	WIRE,ELECTRICAL (8 IN. REQUIRED)	C FT						SEE	GRP	9501					

(1) SMR CODE INDEX NO.	(2) FEDERAL STOCK NUMBER	(3) DESCRIPTION REFERENCE NO. & MFR. CODE	(4) USABLE ON CODE UNIT OF ISSUE	(5) QTY INC IN UNIT PACK	(6) QTY INC IN UNIT	(7) 30-DAY DS MAINT ALLOWANCE (A)	(8) 30-DAY GS MAINT ALLOWANCE (A)	(9) 1-YR PER 100 EQUIP CNTGNCY	(10) DEPOT MAINT ALW- EQUIP	(11) ILLUS- TRATION (A)	(B) (B) ITEM NO.
M O 00297		LEAD, ELECTRICAL: OFF-ON TOGGLE SWITCH TO MAGNETIC STARTER MANUFACTURE FROM:	C EA		1						
X2 O 00298 P O 00299 M O 00300	5940-050-6207 6145-160-5137	TERMINAL, LUG: COPPER, INNED FINISH, NO. 16-14 AWG, FOR NO. 8 SCREW SIZE WIRE, ELECTRICAL (12 IN. REQUIRED)	C EA		2		SEE GRP 9501				
X2 O 00301	5940-050-6207	LEAD, ELECTRICAL: PRESSURE SWITCH TO CONTRACTOR TERMINAL MANUFACTURE FROM: TERMINAL, LUG: COPPER TINNED FINISH, NO. 16-14 AWG, FOR NO. 8 SCREW SIZE	C EA		1						
X2 O 00302	5940-050-6208	TERMINAL, LUG: COPPER, TINNED FINISH, NO. 16-14 AWG, FOR NO. 10 SCREW SIZE	C EA		1						
P O 00303 M O 00304	6145-160-5137	WIRE, ELECTRICAL (16 IN. REQUIRED)	C FT				SEE GRP 9501				
P O 00305 X2 O 00306	6145-161-5415	LEAD, ELECTRICAL: PRESSURE SWITCH TO OFF-ON TOGGLE SWITCH MANUFACTURE FROM: WIRE, ELECTRICAL (4 IN. REQUIRED)	C FT				SEE GRP 9501				
X2 O 00307		MAGNET, MOVABLE L7030W2 (21810)	C EA		1					13	3
X2 O 00308		MAGNET, STATIONERY L7030W1 (21810)	C EA		1					13	27
X2 O 00309		PLATE, IDENTIFICATION: MAGNETIC STARTER X9389X (21810)	C EA		1		SEE GRP 2210				
X2 O 00310		PLATE, LOCK: MOVABLE MAGNET RETAINER C6247V (21810)	C EA		1					13	22
X2 O 00310		PLATE: STARTER BOX MTG C9906W (21810)	C EA		1					13	15

(1) SMR CODE INDEX NO.	(2) FEDERAL STOCK NUMBER	(3) DESCRIPTION	(4) USABLE ON CODE UNIT OF ISSUE	(5) QTY INC IN UNIT PACK	(6) QTY INC IN UNIT	(7) 30-DAY DS MAINT ALLOWANCE (A)	(7) 21-50 (B)	(7) 51-100 (C)	(8) 30-DAY GS MAINT ALLOWANCE (A)	(8) 21-50 (B)	(8) 51-100 (C)	(9) 1-YR ALW PER 100 EQUIP CNTGNCY	(10) DEPOT MAINT ALW- PER 100 EQUIP	(11) ILLUS- TRATION (A)	(11) (B)
		REFERENCE NO. & MFR. CODE				1-20	21-50	51-100	1-20	21-50	51-100			FIG NO.	ITEM NO.
X2 O 00311		RELAY, OVERLOAD: 1H L8833L3	C	EA	1									13	21
X2 O 00312	5305-013-2740	SCREW, MACHINE: MAGNETIC STARTER IDENTIFICATION PLATE MTG	C	EA	1				SEE	GRP	2210				
X2 O 00313	5305-013-2892	SCREW, MACHINE: MAGNETIC STARTER BOX TO MTG PLATE, CADMIUM OR ZINC PLATED, NO. 10-32 THD SIZE, 1/4 IN. LG	C	EA	4									13	25
X2 O 00314	5305-012-2159	SCREW, MACHINE: MAGNETIC STARTER MTG, CADMIUM OR ZINC PLATED, NO. 8-32 THD SIZE, 1/4 IN. LG	C	EA	3										
X2 O 00315	5305-013-2764	SCREW, MACHINE: MAGNETIC STARTER BOX COVER MTG, CADMIUM OR ZINC PLATED: NO. 8-32 THD SIZE, 5/8 IN. LG	C	EA	1										
P O 00316	5340-766-0331	SPRING, HELICAL, COMPRESSION: COIL RETAINER 7224874 (21810)	C	EA	1	*	*	*	*	*	*	5	5	13	4
X2 O 00317	5310-043-2226	WASHER, LOCK: MAGNETIC STARTER BOX TO PLATE MTG, CADMIUM OR ZINC PLATED, 0.194 IN. ID, 0.337 IN. OD, 0.47 IN. THK	C	EA	4									13	26
X2 O 00318	6110-887-4551	STARTER, MAGNETIC 4204AA12J201-26 (21810)	D	EA	1									13	
X2 O 00319		ADAPTER, STRAIGHT, PIPE TO TUBE: AIRE PRESSURE SWITCH TO AIR RECIEVER LINE 1-4X1-8SCB (87005)	D	EA	1									13	18
X2 O 00320		BOX, STRAINER A9913Y (21810)	D	EA	1									13	14
P O 00321	5950-532-7843	COIL, OPERATING ACA126 (21810)	D	EA	1	*	*	*	*	*	*	5	5	13	20
P O 00322	6110-887-2626	CONTACT ASSEMBLY, ELECTRICAL: MOVABLE L6248W2 (21810)	D	EA	2	*	2	2	*	2	2	20	30	13	10
P O 00323	6110-887-2627	CONTACT, ELECTRICAL: STATIONARY LINE L689L2 (21810)	D	EA	2	*	2	2	*	2	2	20	20	13	12
P O 00324	6110-883-4227	CONTACT, ELECTRICAL: STATIONERY LEAD L9290L2 (21810)	D	EA	2	*	2	2	*	2	2	20	20	13	11

(1) SMR CODE INDEX NO.	(2) FEDERAL STOCK NUMBER	(3) DESCRIPTION REFERENCE NO. & MFR. CODE	(4) USABLE ON CODE UNIT OF ISSUE	(5) QTY INC IN UNIT PACK	(6) QTY INC IN UNIT	(7) 30-DAY DS MAINT ALLOWANCE (A)	(8) 30-DAY GS MAINT ALLOWANCE (B)	(9) 1-YR ALW PER EQUIP CNTG	(10) DEPOT MAINT ALW- PER EQUIP	(11) ILLUS- TRATION (A)	(B) ITEM NO.
X2 O 00325		COVER, STARTER A9917X (21810)	D EA		1					13	8
X2 O 00326		DIAGRAM, WIRING WD9920W (21810)	D EA		1		SEE GRP	2210			
X2 O 00327	4730-277-8266	ELBOW, PIPE TO TUBE: AIR PRESSURE SWITCH TO AIR RECEIVER LINE 1-4X1-490DEGCE (87005)	D EA		1					13	16
P O 00328	6110-532-7789	HEATER, OVERLOAD: MAGNETIC STARTER F28 (21810)	D EA		1	* 2 2	* 2 2	10	10	13	6
P O 00329	6110-887-4466	HEATER, OVERLOAD: MAGNETIC STARTER F14-2 (21810)	D EA		1	* 2 2	* 2 2	10	10	13	6
X2 O 00330		LEAD 14TW4 (11568)	D EA		1					13	1
X2 O 00331	6145-160-5137	LEAD, CONTROL 14TWB0DEGC (21810)	D EA		2					13	9
X2 O 00332	6145-295-1309	LEAD, POWER 10TW90DEGCSOL (21810)	D EA		1					13	5
X2 O 00333		MAGNET, MOVABLE L7030W2 (21810)	D EA		1					13	3
X2 O 00334		MAGNETIC, STATIONARY L7030W1 (21810)	D EA		1					13	27
X2 O 00335		NUT, LOCK: OFF-ON SWITCH MTG 1-2CLN (74545)	D EA		2						
X2 O 00336		PLATE, IDENTIFICATION: MAGNETIC STARTER Y9389X (21810)	D EA		1		SEE GRP	2210			
X2 O 00337		PLATE, LOCK: MOVABLE MAGNETIC RETAINER C6247W (21810)	D EA		1					13	22
X2 O 00338		PLATE, MOTOR MOUNTING 09906W (21810)	D EA		1					13	15

(1) SMR CODE INDEX NO.	(2) FEDERAL STOCK NUMBER	(3) DESCRIPTION REFERENCE NO. & MFR. CODE	(4) USABLE ON CODE UNIT OF ISSUE	(5) QTY INC IN UNIT PACK	(6) QTY INC IN UNIT	(7) 30-DAY DS MAINT ALLOWANCE (A)	(8) 30-DAY GS MAINT ALLOWANCE (B)	(9) 1-YR ALW PER EQUIP CNTGNCY	(10) DEPOT MAINT ALW- PER EQUIP	(11) ILLUS- TRATION (A)	(11) ITEM NO. (B)
X2 O 00339	5945-020-6725	RELAY, OVERLOAD: 1H L8833L3 (21810)	D EA		1	1-20	21-50	51-100		13	21
X2 O 00340	5305-013-2740	SCREW, MACHINE: MAGNETIC STARTER IDENTIFICATION PLATE MTG	D EA		1		SEE	GRP	2210		
P O 00341	2920-834-8474	SET, RENEWAL AR3 (21810)	D EA		1	*	2	2	* 2 2	20	30
X1 00342	6110-887-2627	CONTACT L6289L2 (21810)	D EA		4						
X1 00343	6110-883-4227	CONTACT L6290L2 (21810)	D EA		4						
X1 00344	6110-887-2626	FINGER ASSEMBLY L6248W2 (21810)	D EA		4						
X2 O 00345	5340-766-0331	SPRING, COIL RETAINER 7224874 (21810)	D EA		1					13	4
X2 O 00346	5930-241-8921	SWITCH, OFF-ON 2DA25-73 (73559)	D EA		1						
P O 00347	5930-430-4071	SWITCH, PRESSURE: MAGNETIC SWITCH HL (23826)	D EA		1	*	2	2	* 2 2	10	10 13 2
X2 O 00348		TUBE, PRESSURE: ALUMINUM 1-4X8-1-2AT (11568)	D EA		1						13 17
X2 O 00349		WASHER: OFF-ON SWITCH MTG, 3/4 X 1/2 IN. 3-4X1-2CRW (74545)	D EA		2						
X2 O 00350	6110-887-4744	STARTER, MAGNETIC 4204AA13J201-51 (21810)	E EA		1						13
X2 O 00351		ADAPTER, STRAIGHT, PIPE TO TUBE M408 (11568)	E EA		1						13 18
X2 O 00352		BOX, STARTER A9913Y (21810)	E EA		1						13 14

(1) SMR CODE INDEX NO.	(2) FEDERAL STOCK NUMBER	(3) DESCRIPTION REFERENCE NO. & MFR. CODE	(4) USABLE ON CODE UNIT OF ISSUE	(5) QTY INC IN UNIT PACK	(6) QTY INC IN UNIT	(7) 30-DAY DS MAINT ALLOWANCE (A)	(7) 21-50 (B)	(7) 51-100 (C)	(8) 30-DAY GS MAINT ALLOWANCE (A)	(8) 21-50 (B)	(8) 51-100 (C)	(9) 1-YR ALW PER 100 EQUIP CNTGCTY	(10) DEPOT MAINT ALW- PER 100 EQUIP	(11) ILLUS- TRATION (A)	(11) (B)	FIG NO.	ITEM NO.
P O 00353	6110-887-2623	COIL, MAGNETIC STARTER ACA151 (21810)	E EA	1		*	*	*	*	*	*	5	5	13	20		
P O 00354	6110-887-2626	CONTACT ASSEMBLY, ELECTRICAL: MOVABLE L6248W2 (21810)	E EA	3		2	2	3	2	2	3	30	15	13	10		
P O 00355	6110-887-2627	CONTACT, ELECTRICAL: STATIONARY LINE L6289L2 (21810)	E EA	3		2	2	3	2	2	3	30	30	13	12		
P O 00356	6110-883-4227	CONTACT, ELECTRICAL: STATIONARY LOAD L6290L2 (21810)	E EA	3		2	2	3	2	2	3	30	30	13	11		
X2 O 00357		COVER, STARTER Z9917X (21810)	E EA	1										13	8		
X2 O 00358		DIAPGRAM, WIRING WD9920W (21810)	E EA	1					SEE	GRP	2210						
X2 O 00359		ELBOW: AIR RECEIVER LINE M499 (11568)	E EA	1										13	16		
P O 00360	4310-877-2625	HEATER, OVERLOAD: MAGNETIC STARTER FA0 (21810)	E EA	2		*	2	2	*	2	2	20	10	13	6		
P O 00361	4310-877-2624	HEATER, OVERLOAD: MAGNETIC STARTER, 416V F4-0 (21810)	E EA	2		*	2	2	*	2	2	20	10	13	6		
P O 00362	6145-542-6039	LEAD, CONTROL 10TW80CSTR (21810)	E EA	1		*	*	2	*	*	2	10	50	13	9		
P O 00363	6145-542-6039	LEAD, POWER 10TW90CS0L (21810)	E EA	1		*	*	2	*	*	2	10	50	13	5		
X2 O 00364		MAGNET, STATIONARY L7030W1 (21810)	E EA	1										13	27		
X2 O 00365		NUT: TUBE M27 (11568)	E EA	2													
X2 O 00366		PLATE, IDENTIFICATION: MAGNETIC STARTER Y9389X (21810)	E EA	1					SEE	GRP	2210						

(1) SMR CODE INDEX NO.	(2) FEDERAL STOCK NUMBER	(3) DESCRIPTION	(4) USABLE ON CODE UNIT OF ISSUE	(5) QTY INC IN UNIT PACK	(6) QTY INC IN UNIT	(7) 30-DAY DS MAINT ALLOWANCE (A) (B) (C)	(8) 30-DAY GS MAINT ALLOWANCE (A) (B) (C)	(9) 1-YR ALW PER 100 EQUIP CNTGNCY	(10) 1-YR DEPOT MAINT ALW- PER 100 EQUIP	(11) ILLUS- TRATION (A) (B) FIG NO. ITEM NO.
X2 O 00367		PLATE, LOCK: MOVABLE MAGNETIC RETAINER C6247V (21810)	E EA		1					13 22
X2 O 00368		PLATE, MOTOR MOUNTING C9906W (21810)	E EA		1					13 15
X2 O 00369		RELAY, OVERLOAD: 1H L8833L3 (21810)	E EA		1					13 21
X2 O 00370		RELAY, OVERLOAD: 1H L8833L4 (21810)	E EA		1					13 13
X2 O 00371	5340-766-0331	SPRING: COIL RETAINER	E EA		1					13 4
X2 O 00372		SWITCH, OFF-ON 2DA25-73 (73559)	EA	1						
P O 00373	5930-430-4071	SWITCH, PRESSURE: MAGNETIC SWITCH H1 (23826)	E EA		1	* 2 2	* 2 2	10	10	13 2
X2 O 00374	5305-013-2740	SCREW, MACHINE: MAGNETIC STARTER IDENTIFICATION PLATE MTG	E EA		11		SEE GRP	2210		
X2 O 00375		TUBE 1-4X8 (11568)	E EA		1					13 17
X2 O 00376	5930-430-4071	SWITCH, PRESSURE: MAGNETIC STARTER H1 (23826) (INCLUDES COMPONENTS OF REPAIR KIT, STOCK NO. 5930-521-8471)	BC EA		1					13 2
M O 00377		TUBE, PRESSURE: AIR PRESSURE SWITCH TO AIR RECEIVER 1-4X101-2TA (11568) MANUFACTURE FROM:	BC EA		1					13 17
X2 O 00378	4730-142-1593	INVERTED NUT, TUBE COUPLING: BRASS, 1/4 IN. TUBE, 7/16-24 THD SIZE	BC EA		2					
P O 00379 00380	4710-278-6398	TUBE, ALUMINUM (10 IN. REQUIRED) 4012-SWITCHES	BC FT				SEE GRP	9501		
X2 O 00381		SWITCH, TOGGLE: OFF-ON ZDA26-73 (73559)	C EA		1					

(1) SMR CODE INDEX NO.	(2) FEDERAL STOCK NUMBER	(3) DESCRIPTION	(4) REFERENCE NO. & MFR. CODE USABLE ON CODE	UNIT OF ISSUE	(5) QTY INC IN UNIT PACK	(6) QTY INC IN UNIT	(7) 30-DAY DS MAINT ALLOWANCE (A)	(B)	(C)	(8) 30-DAY GS MAINT ALLOWANCE (A)	(B)	(C)	(9) 1-YR ALW PER 100 EQUIP CNTGNCY	(10) DEPOT MAINT ALW- PER 100 EQUIP	(11) ILLUS- TRATION (A)	(B)	FIG NO.	ITEM NO.
00382		GROUP 47 - GAGES (NON-ELECTRICAL), WEIGHING AND MEASURING DEVICES					1-20	21-50	51-100	1-20	21-50	51-100						
00383		4702 - GAGES, MOUNTINGS, LINES AND FITTINGS																
X2 O 00384		BRACKET: AIR PRESSURE GAGE MTG M641 (11568)	AF	EA	1												7	15
O 00385	4730-246-9215	ELBOW, PIPE: AIR PRESSURE GAGE HOSE ASSEMBLY TO RECEIVER	AF	EA	1	*	*	*	*	*	*	*	*	*	*	*	7	29
P O 00386	6685-514-3709	GAGE, PRESSURE, DIAL INDICATING: AIR PRESSURE, RECEIVER, 0-300 LB, 1/4-18 THD SIZE N060 (11568)	B	EA	1	*	*	*	*	*	*	*	3	3			15	4
P O 00387	6685-264-3961	GAGE, PRESSURE, DIAL INDICATING: AIR RECEIVER M519C (11568)	AF	EA	1	*	*	*	*	*	*	*	5	5			7	13
P O 00388	6685-264-3961	GAGE,PRESSURE, DIAL INDICATING: AIR RECEIVER M519 (11568)	E	EA	1	*	*	*	*	*	*	*	5	5			15	4
P O 00389	6685-264-3961	GAGE, PRESSURE, DIAL INDICATING: AIR RECEIVER M519C (11568)	CD	EA	1	*	*	*	*	*	*	*	5	3			15	4
P O 00390	4310-327-6438	HOSE, ASSEMBLY, GAGE: RECEIVER Z260 (11568)	AF	EA	1	*	2	2	*	2	2	20	10				7	16
O 00391	5310-269-5914	WASHER,FLAT: HOSE ASSEMBLY TO MTG BRACKET	AF	EA	1	*	*	*	*	*	*	*	*	*	*	*	7	14
00392		GROUP 50 - PNEUMATIC EQUIPMENT																
00393		5000 - AIR COMPRESSOR ASSEMBLY																
X2 OR 00394	4310-987-2742	COMPRESSOR, AIR: ELECTRIC MOTOR DRIVEN NR150 (11568)	BC	EA	1													1
X2 OR 00395		COMPRESSOR, AIR: ELECTRIC MOTOR DRIVEN NR150A (11568)	DE	EA	1													1
X2 OR 00396		COMPRESSOR, AIR: GASOLINE ENGINE DRIVEN NR150AL (11568)	F	EA	1													1
X2 OR 00397	4310-902-2447	COMPRESSOR, AIR: GASOLINE ENGINE DRIVEN NR150L (11568)	A	EA	1													1

(1) SMR CODE INDEX NO.	(2) FEDERAL STOCK NUMBER	(3) DESCRIPTION REFERENCE NO. & MFR. CODE	(4) USABLE ON CODE UNIT OF ISSUE	(5) QTY INC IN UNIT PACK	(6) QTY INC IN UNIT	(7) 30-DAY DS MAINT ALLOWANCE (A)	(7) 21-50 (B)	(7) 51-100 (C)	(8) 30-DAY GS MAINT ALLOWANCE (A)	(8) 21-50 (B)	(8) 51-100 (C)	(9) 1-YR ALW PER 100 EQUIP CNTG	(10) 1-YR DEPOT MAINT ALW- PER 100 EQUIP	(11) ILLUS- TRATION (A)	(11) (B) ITEM NO.
P O 00398	4310-882-5057	GASKET SET: AIR COMPRESSOR Z253 (11568)	ABC EA		1	2	4	8	2	4	8	100	100		
X1 00399	4310-657-7413	GASKET: CYLINDER FLANGE SE14-29 (11568)	ABC EA		1				SEE	GRP	5001				
X1 00400	4310-585-4283	GASKET: GOVERNOR HOUSING SE14-89 (11568)	ABC EA		1				SEE	GRP	5009				
X1 00401	4310-585-9951	GASKET: HANDHOLE PLATE, CRANKCASE SE14-31 (11568)	ABC EA		1				SEE	GRP	5001				
X1 00402	5330-584-9000	GASKET: OIL FILLER CAP SE30-18 (11568)	ABC EA		1				SEE	GRP	5006				
X1 00403	4310-654-3588	GASKET: OIL FILLER HANDHOLE PLATE, CRANKCASE SE14-33 (11568)	ABC EA		1				SEE	GRP	5001				
X1 00404	4310-633-6114	GASKET: SHIM, GOVERNOR HOUSING (SET OF 3) SE14-30A (11568)	ABC EA		1				SEE	GRP	5009				
P O 00405	4310-066-4206	GASKET SET: AIR COMPRESSOR Z253A (11568)	DEF EA		1	2	4	8	2	4	8	100	100		
X1 00406	4310-657-7413	GASKET: CYLINDER FLANGE SE14-29 (11568)	DEF EA		1				SEE	GRP	5001				
X1 00407		GASKET: GOVERNOR HOUSING SE14-89 (11568)	DEF EA		1				SEE	GRP	5009				
X1 00408	5310-058-3651	GASKET: GOVERNOR UNLOADER SPRING SE5-88 (11568)	DEF EA		1				SEE	GRP	5009				
X1 00409	4310-585-7546	GASKET: HANDHOLE PLATE NR31 (11568)	DEF EA		2				SEE	GRP	5001				
X1 00410		GASKET: SHIM, GOVERNOR SE14-30A (11568)	DEF EA		1				SEE	GRP	5009				
X1 00411		GASKET (1) H122 (11568)	DEF EA		0										
P O 00412	4310-887-2622	KIT, VALVE ASSEMBLY Z124 (11568)	E EA		1	2	2	3	2	2	3	30	50		

(1) SMR CODE INDEX NO.	(2) FEDERAL STOCK NUMBER	(3) DESCRIPTION	(4) USABLE ON CODE UNIT OF ISSUE		(5) QTY INC IN UNIT PACK	(6) QTY INC IN UNIT	(7) 30-DAY DS MAINT ALLOWANCE			(8) 30-DAY GS MAINT ALLOWANCE			(9) 1-YR ALW PER 100 EQUIP CNTGNCY	(10) DEPOT MAINT ALW- PER 100 EQUIP	(11) ILLUS- TRATION (A) (B) FIG NO. ITEM NO.	
		REFERENCE NO. & MFR. CODE					1-20	21-50	51-100	1-20	21-50	51-100				
X1 00413	3110-606-8365	BALL, BEARING: RELIEF VALVE SE5-95 (11568)	E	EA		1				SEE	GRP	5009				
X1 00414	4310-625-6749	BODY, RELEASE VALVE SE30-101 (11568)	E	EA		1				SEE	GRP	5009				
X1 00415		CAP, RELIEF VALVE SE5-85 (11568)	E	EA		1				SEE	GRP	5009				
X1 00416	5330-298-5554	GASKET: RELEASE VALVE BODY MI22 (11568)	E	EA		1				SEE	GRP	5009				
X1 00417	4310-654-3589	PLUNGER, RELIEF VALVE SE5-86A (11568)	E	EA		1				SEE	GRP	5009				
X1 00418	4310-625-6748	SLEEVE, PLUNGER: RELIEVE VALVE SE5-97 (11568)	E	EA		1				SEE	GRP	5009				
X1 00419	4310-616-4373	SPRING, RELIEVE VALVE SE5-91 (11568)	E	EA		1				SEE	GRP	5009				
O 00420	5310-732-0558	NUT, PLAIN, HEXAGON: COMPRESSOR MTG	BCE	EA		4	*	*	*	*	*	*	*	*	1	16
X2 O 00421	5310-010-2635	NUT, PLAIN, HEXAGON: COMPRESSOR MTG 3-8N (87764)	D	EA		4									1	16
O 00422	5310-050-3275	NUT, PLAIN, HEXAGON: AIR COMPRESSOR MTG	AF	EA		4	*	*	*	*	*	*	*	*	1	16
O 00423	5305-269-3213	SCREW, CAP, HEXAGON HEAD: AIR COMPRESSOR MTG	BC	EA		4	*	*	*	*	*	*	*	*	1	15
X2 O 00424	5305-065-6800	SCREW, CAP, HEXAGON HEAD: COMPRESSOR MTG 3-8-16X1-1-4CS (87764)	D	EA		4									1	15
O 00425	5305-021-5466	SCREW, CAP, HEXAGON HEAD: COMPRESSOR MTG	F	EA		4	*	*	*	*	*	*	*	*	1	15
X2 O 00426		SCREW, CAP, HEXAGON HEAD: COMPRESSOR MTG, CADIMUM OR ZINC PLATED, 3/8-16 THD SIZE, 2 IN. LG	A	EA		4									1	15
O 00427	5310-087-7493	WASHER, FLAT: AIR COMPRESSOR MTG	BC	EA		4	*	*	*	*	*	*	*	*	1	18
O 00428	5310-637-9541	WASHER, LOCK: AIR COMPRESSOR MTG	BC	EA		4	*	*	*	*	*	*	*	*	1	17

(1) SMR CODE INDEX NO.	(2) FEDERAL STOCK NUMBER	(3) DESCRIPTION REFERENCE NO. & MFR. CODE	(4) USABLE ON CODE UNIT OF ISSUE	(5) QTY INC IN UNIT PACK	(6) QTY INC IN UNIT	(7) 30-DAY DS MAINT ALLOWANCE (A) (B) (C)	(8) 30-DAY GS MAINT ALLOWANCE (A) (B) (C)	(9) 1-YR ALW PER 100 EQUIP CNTG	(10) DEPOT MAINT ALW- PER 100 EQUIP	(11) ILLUS- TRATION (A) (B) FIG NO. ITEM NO.	
X2 O 00429		WASHER, LOCK: COMPRESSOR MTG MS35338-8 (96906)	D EA		4					1 17	
X2 O 00430	5310-582-3341	WASHER, LOCK: COMPRESSOR MTG 3-8LW (11568)	E EA		8					1 17	
00431		5001 - CRANKCASE, BLOCK, CYLINDER HEAD									
X2 F 00432	4310-887-8764	BLOCK, CYLINDER: AIR COMPRESSOR RE4-6BL (11568)	AF EA		1			3		1 6	
X2 F 00433	4310-799-0812	BLOCK, CYLINDER: AIR COMPRESSOR, CASE IRON RE4-6B (11568)	BCDE EA		1					1 6	
O 00434	5306-017-9818	BOLT, MACHINE: HANDHOLE PLATE MTG	F EA		12	*	*	*	*	*	1 22
O 00435	5306-225-8497	BOLT, MACHINE: HANDHOLE PLATE MTG	A EA		10	*	*	*	*	*	1 22
O 00436	5306-225-8499	BOLT, MACHINE: HANDHOLE PLATE MTG	D EA		12	*	*	*	*	*	1 22
O 00437	5306-225-8499	BOLT, MACHINE: HANDHOLE PLATE MTG	BC EA		10	*	*	*	*	*	1 22
X2 O 00438		BOLT, MACHINE: HANDHOLE PLATE MTG M567 (11568)	E EA		12						1 22
O 00439	4730-228-1621	CAP, PIPE: AIR COMPRESSOR OIL DRAIN	EA		1	*	*	*	*	*	1 14
X2 O 00440		CAP, PIPE: COMPRESSOR OIL DRAIN M461 (14959)	E EA		1						1 14
X2 O 00441		CAP, PIPE: OIL DRAIN, 3/8 IN. PF33 (14959)	F EA		1						1 14
X2 O 00442	4730-288-1619	CAP, PIPE: OIL DRAIN, 3/8 IN.	D EA		1						1 14
X2 FR 00443		CRANKCASE NR4-9 (11568)	DE EA		1						1 19
X2 FR 00444		CRANKCASE: AIR COMPRESSOR RE4-9AL (11568)	A EA		1						1 19
X2 FR 00445		CRANKCASE: AIR COMPRESSOR NR4-9L (11568)	F EA		1						1 19

(1) SMR CODE INDEX NO.	(2) FEDERAL STOCK NUMBER	(3) DESCRIPTION	(4) USABLE ON CODE UNIT OF ISSUE	(5) QTY INC IN UNIT PACK	(6) QTY INC IN UNIT	(7) 30-DAY DS MAINT ALLOWANCE (A)	(8) 30-DAY GS MAINT ALLOWANCE (B)	(9) 1-YR ALW PER EQUIP CNTGNCY	(10) DEPOT MAINT ALW- PER EQUIP	(11) ILLUS- TRATION (A)	(B) (B) ITEM NO.			
		REFERENCE NO. & MFR. CODE				1-20	21-50	51-100	1-20	21-50	51-100	FIG NO.	ITEM NO.	
X2 F 00446		CRANKCASE: AIR COMPRESSOR, CAST IRON RE4-9A (11568)	BC EA		1							1	19	
X1 00447	4310-657-7413	GASKET: CYLINDER FLANGE SE14-29 (11568) (COMPONENT OF GASKET SET, STOCK NO. 4310-066-4206, AND GASKET SET, STOCK NO. 4310-882-5057, SEE GROUP 5000)	EA		1							1	7	
X1 00448	4310-585-7546	GASKET: HANDHOLE PLATE NR31 (11568) (COMPONENT OF GASKET SET, STOCK NO. 4310-066-4206, SEE GROUP 5000)	DEF EA		2							1	8	
X1 00449	4310-585-9951	GASKET: HANDHOLE PLATE, CRANKCASE SE14-31 (11568) (COMPONENT OF GASKET SET, STOCK NO. 4310-066-4206, SEE GROUP 5000)	ABC EA		1							1	8	
X1 00450	4310-654-3588	GASKET: OIL FILLER HANDHOLE PLATE, CRANKCASE SE14-33 (11568) (COMPONENT OF GASKET SET, STOCK NO. 4310-066-4206, SEE GROUP 5000)	ABC EA		1							1	20	
O 00451	4730-277-9997	NIPPLE, PIPE: AIR COMPRESSOR OIL DRAIN	EA		1	*	*	*	*	*	*	*	1	13
X2 O 00452		NIPPLE, PIPE: OIL DRAIN M460 (11568)	E EA		1							1	13	
X2 O 00453		NIPPLE, PIPE: OIL DRAIN, 3/8 IN. X 5 IN. PF13J (14959)	DF EA		1							1	13	
F 00454	5310-021-8585	NUT, PLAIN, HEXAGON: CYLINDER BLOCK TO CRANKCASE MTG	ABE EA		6	*	*	*	*	*	*	*	1	5
X2 O 00455		PLATE, HANDHOLE: CRANKCASE SE14-15L (11568)	A EA		1							1	9	
X2 O 00456		PLATE, HANDHOLE: CRANKCASE NR15 (11568)	DEF EA		2							1	9	
X2 O 00457		PLATE, HANDHOLE: CRANKCASE, CAST IRON SE14-15 (11568)	BC EA		1							1	9	
X2 O 00458		PLATE, HANDHOLE: CRANKCASE, W/OIL FILLER SE14-15B (11568)	C EA		1							1	21	

(1) SMR CODE INDEX NO.	(2) FEDERAL STOCK NUMBER	(3) DESCRIPTION	(4) USABLE ON CODE UNIT OF ISSUE	(5) QTY INC IN UNIT PACK	(6) QTY INC IN UNIT	(7) 30-DAY DS MAINT ALLOWANCE (A)	(7) 1-YR MAINT ALLOWANCE (B)	(7) 51-100 (C)	(8) 30-DAY GS MAINT ALLOWANCE (A)	(8) 21-50 (B)	(8) 51-100 (C)	(9) 1-YR ALW PER 100 EQUIP CNTGNCY	(10) DEPOT MAINT ALW- PER 100 EQUIP	(11) ILLUS- TRATION (A)	(11) (B)
		REFERENCE NO. & MFR. CODE				1-20	21-50	51-100	1-20	21-50	51-100		FIG NO.	ITEM NO.	
X2 O 00459		PLATE, HANDHOLE, OIL FILLER: CRANKCASE SE14-15BL (11568)	A EA		1								1	21	
X2 O 00460		PLATE, HANDHOLE, OIL FILLER: CRANKCASE, CAST IRON SE14-15B (11568)	B EA		1								1	21	
X2 F 00461		STUD, PLAIN: CRANKCASE TO CYLINDER BLOCK, BOTH ENDS, 7/16-20 THD SIZE, 2 IN. LG SE5-78 (11568)	ABE EA		6								1	4	
O 00462	5307-850-0308	STUD, PLAIN: MANIFOLDS MTG	EA		8	*	*	*	*	*	*	*	5	11	
X2 O 00463	5307-732-4920	STUD, PLAIN: MANIFOLD MTG SE572 (11568)	E EA		8								5	11	
P F 00464	6680-377-4915	WINDOW, OBSERVATION: OIL LEVEL, 1 1/4 IN. PD. 11/32 IN. THK B5093 (70925)	EA		1	*	*2	*	*	2	10	5	1	12	
		5002 - CRANKSHAFT													
P F 00466	3110-144-8534	BEARING, BALL, ANNULAR: CRANKSHAFT 3207 (43334)	EA		2	*	2	2	*	2	2	20	30	2	
A F 00467		BEARING, MAIN: CRANKSHAFT LM48500 (60038)	DEF EA		2									2	
P F 00468	3110-586-8305	CONE: BEARING ASSEMBLY LM48548 (60038)	DEF EA		2	*	*	2	*	*	2	10	30		
P F 00469	3110-586-8306	CUP: BEARING ASSEMBLY LM48510 (60038)	DEF EA		2	*	*	2	*	*	2	10	30		
X2 F 00470	4310-025-6328	CRANKSHAFT AIR COMPRESSOR NR4-5 (11568)	EA		1								4	2	
X2 F 00471		CRANKSHAFT: COMPRESSOR NR4-5B (11568)	DF EA		1									2	
X2 F 00472		CRANKSHAFT: COMPRESSOR NR4-5B (11568)	E EA		1									2	
X2 O 00473		KEY: FLYWHEEL H18 (11568)	DEF EA		1									1	

(1) SMR CODE INDEX NO.	(2) FEDERAL STOCK NUMBER	(3) DESCRIPTION REFERENCE NO. & MFR. CODE	(4) USABLE ON CODE UNIT OF ISSUE	(5) QTY INC IN UNIT PACK	(6) QTY INC IN UNIT	(7) 30-DAY DS MAINT ALLOWANCE (A)	(7) 30-DAY DS MAINT ALLOWANCE (B)	(7) 30-DAY DS MAINT ALLOWANCE (C)	(8) 30-DAY GS MAINT ALLOWANCE (A)	(8) 30-DAY GS MAINT ALLOWANCE (B)	(8) 30-DAY GS MAINT ALLOWANCE (C)	(9) 1-YR ALW PER 100 EQUIP CNTGNCY	(10) DEPOT MAINT ALW- PER 100 EQUIP	(11) ILLUS- TRATION (A)	(11) ITEM NO. (B)
X2 O 00474		KEY, MACHINE: PLYWHEEL, 2 IN. LG, 1/4 IN. SQ. SE5-8 (11568)	EA		1									1	3
P F 00475	5330-724-0793	SEAL: CRANKSHAFT OSN4 (11568)	DEF EA		1	*	2	2	*	2	2	20	100	2	1
P F 00476	5330-724-0793	SEAL, PLAIN, ENCASED: CRANKSHAFT 212W112 (80201)	EA		1	2	4	8	2	4	8	100	100	2	1
00477		5004 - PISTONS, CONNECTING, RODS AND ROTORS													
P F 00478	4310-654-3593	PISTON ASSEMBLY, COMPRESSOR: HIGH PRESSURE Z7-4C (11568)	EA		1	*	*	*	*	*	*	5	35	2	21
X1 00479		PIN, PISTON RE7-21C (11568)	EA		1									2	19
X1 00480		PISTON, HIGH PRESSURE RE7-4C (11568)	EA		1									2	20
X1 00481		RING, RETAINING 5000-75 (97464)	EA		2									2	18
P F 00482	4310-654-3592	PISTON ASSEMBLY, COMPRESSOR: LOW PRESSURE Z5-4C (11568)	EA		1	*	*	*	*	*	*	5	35	2	31
X1 00483		PIN, PISTON SE5-21A (11568)	EA		1									2	29
X1 00484		PISTON, LOW PRESSURE 5000-93 (97464)	EA		1									2	30
P F 00486	4310-649-8397	RING, SET, PISTON: HIGH PRESSURE Z187A (11568)	EA		1	*	*	*	*	*	*	5	100	2	24
X1 00487		RING, COMPRESSION 20B263 (11568)	EA		2									2	23
X1 00488		RING, OIL 71048 (11568)	EA		1									2	22

(1) SMR CODE INDEX NO.	(2) FEDERAL STOCK NUMBER	(3) DESCRIPTION REFERENCE NO. & MFR. CODE	(4) USABLE ON CODE UNIT OF ISSUE	(5) QTY INC IN UNIT PACK	(6) QTY INC IN UNIT	(7) 30-DAY DS MAINT ALLOWANCE (A)	(7) 21-50 (B)	(7) 51-100 (C)	(8) 30-DAY GS MAINT ALLOWANCE (A)	(8) 21-50 (B)	(8) 51-100 (C)	(9) 1-YR ALW PER 100 EQUIP CNTG	(10) DEPOT MAINT ALW- PER 100 EQUIP	(11) ILLUS- TRATION (A)	(11) (B) ITEM NO.
P F 00489	4310-066-4950	RING SET: HIGH PRESSURE Z187B (11568)	DEF	EA	2	*	*	*	*	*	*	5	100	2	24
X1 00490		RING, COMPRESSION, LOWER RE7-10B (11568)	DEF	EA	1									2	23
X1 00491		RING, COMPRESSION, TOP RE7-10A (11568)	DEF	EA	1									2	23
X1 00492		RING, OIL RE7-10C (11568)	DEF	EA	1									2	22
P F 00493	4310-649-8396	RING SET, PISTON: LOW PRESSURE Z177A (11568)	DEF	EA	1	*	*	*	*	*	*	5	100	2	27
X1 00494		RING, COMPRESSION 91-20281 (11568)	DEF	EA	2									2	25
X1 00495		RING, OIL 72B507 (11568)	DEF	EA	2									2	26
P F 00496	4310-066-6039	RING SET: LOW PRESSURE Z177B (11568)	DEF	EA	1	*	*	*	*	*	*	5	100	2	27
X1 00497		RING, COMPRESSION, LOWER SE5-10B (11568)	DEF	EA	1									2	25
X1 00498		RING, COMPRESSION, TOP SE5-10A (11568)	DEF	EA	1									2	25
X1 00499		RING, OIL SE5-10C (11568)	DEF	EA	2									2	26
X2 F 00500	4310-976-0783	ROD ASSEMBLY, HIGH PRESSURE Z10-3A (11568)	DEF	EA	1									2	13
P F 00501	4310-631-9407	BEARING, SLEEVE: CONNECTING ROD SE5-38 (11568)	DEF	EA	1				SEE	GRP	9901			2	4
P F 00502	4310-811-6046	BEARING, SLEEVE: PISTON PIN RE10-37 (11568)	DEF	EA	1	*	*	*	*	*	*	5	100	2	17

(1) SMR CODE INDEX NO.	(2) FEDERAL STOCK NUMBER	(3) DESCRIPTION REFERENCE NO. & MFR. CODE	(4) USABLE ON CODE UNIT OF ISSUE	(5) QTY INC IN UNIT PACK	(6) QTY INC IN UNIT	(7) 30-DAY DS MAINT ALLOWANCE (A)	(8) 30-DAY GS MAINT ALLOWANCE (A)	(9) 1-YR ALW PER EQUIP CNTGNCY	(10) DEPOT MAINT ALW- PER EQUIP	(11) ILLUS- TRATION (A)	(B) ITEM NO.				
X2 F 00503		BOLT, CONNECTING ROD: STEEL, 3/8-24 THD SIZE, 2 1/4 IN. LG SE30-20 (11568)	EA		2	1-20	21-50	51-100			2	16			
X2 F 00504		NUT, PLAIN, HEXAGON: CONNECTING ROD BOLT, 3/8-24 THD SIZE M467 (11568)	EA		2						2	9			
X1 00505		ROD, CONNECTING RE10-3A (11568)	EA		1						2	11			
X2 F 00506		SCOOP, OIL, CONNECTING ROD RE10-24 (11568)	EA		1						2	12			
P F 00507	4310-646-9749	SHIM: CONNECTING ROD BEARING N39 (11568)	EA		2			SEE GRP 9901			2	5			
X2 F 00508		WASHER, LOCK: CONNECTING ROD BOLT, 0.382 IN. ID, 0.688 IN. OD, 0.094 IN. THK M468 (11568)	EA		2						2	8			
X2 F 00509	4310-930-8106	ROD ASSEMBLY, LOW PRESSURE Z5-3A (11568)	EA		1						2	10			
P F 00510	4310-631-9407	BEARING, SLEEVE: CONNECTING ROD SE5-38 (11568)	EA		1			SEE GRP 9901			2	4			
P F 00511	4310-555-4540	BEARING, SLEEVE: PISTON PIN SE5-37 (11568)	EA		1	*	*	2	*	*	2	10	100	2	15
X2 F 00512		BOLT, CONNECTING ROD: STEEL, 3/8-24 THD SIZE, 2 1/8 IN. LG SE5-20 (11568)	EA		2						2	14			
X2 F 00513		NUT, PLAIN, HEXAGON: CONNECTING ROD BOLT, 3/8-24 THD SIZE M467 (11568)	EA		2						2	9			
F 00514	5315-846-4888	PIN, STRAIGHT, THREADED	EA		1	*	*	*	*	*	*	2	7		
X1 00515		ROD, CONNECTING SE5-3A (11568)	EA		1						2	6			

(1) SMR CODE INDEX NO.	(2) FEDERAL STOCK NUMBER	(3) DESCRIPTION REFERENCE NO. & MFR. CODE	(4) USABLE ON CODE UNIT OF ISSUE	(5) QTY INC IN UNIT PACK	(6) QTY INC IN UNIT	(7) 30-DAY DS MAINT ALLOWANCE (A)	(7) 21-50 (B)	(7) 51-100 (C)	(8) 30-DAY GS MAINT ALLOWANCE (A)	(8) 21-50 (B)	(8) 51-100 (C)	(9) 1-YR ALW PER 100 EQUIP CNTGNCY	(10) DEPOT MAINT ALW- PER 100 EQUIP	(11) ILLUS- TRATION (A)	(11) (B)
P F 00516	4310-646-9749	GASKET, VALVE SHIM: CONNECTING ROD BEARING N39 (11568)	EA		2				SEE	GRP	9901			2	5
F 00517 00518	5310-261-7340	WASHER, LOCK: CONNECTING ROD BOLT 5005 - VALVES, CAMSHAFT AND TIMING MECHANISM	EA		2	*	*	*	*	*	*	*	*	2	8
P O 00519	5330-882-5056	GASKET SET: VALVE Z100G (11568)	D EA		1		4	8	2	4	8	100	100		
X1 00520	5330-239-1792	GASKET, VALVE RE10-66 (11568)	D EA		4									3	8
X1 00521	5330-599-5888	GASKET, VALVE SE5-28 (11568)	D EA		4									3	1
P O 00522	5330-584-9010	GASKET, VALVE Z165 (79150)	EA		4	2	4	8	2	4	8	100	400	3	8
P O 00523	5330-599-5888	GASKET, VALVE Z185 (79150)	EA		4	2	4	8	2	4	8	100	400	3	1
P O 00524	4310-654-3590	VALVE ASSEMBLY, AIR: LOW PRESSURE INTAKE Z114 (11568) (INCLUDES COMPONENTS OF GASKET SET, STOCK NO. 5330-882-5056) (SAME AS VALVE ASSEMBLY, STOCK NO. 4310-631-3397, EXCEPT WHERE INDIVIDUAL COMPONENTS ARE ANNOTATED)	EA		1	*	*	*	*	*	*	5	100	3	13
P O 00525	4310-631-3396	VALVE ASSEMBLY, DISCHARGE: HIGH AND LOW PRESSURE Z115 (11568) (INCLUDES COMPONENTS OF GASKET SET, STOCK NO. 5330-584-9000)	EA											3	9
X1 00526	4310-625-6753	CAGE, EXHAUST VALVE: HIGH AND LOW PRESSURE RE7-53A (11568)	EA		2									3	4
X1 00527	5310-625-6755	DISK, HIGH PRESSURE INTAKE AND EXHAUST VALVE RE10-62 (11568)	EA		2									3	6
O 00528 X1 00529	5305-013-2900	SCREW, MACHINE: VALVE CAGE	EA		2	*	*	*	*	*	*	*	*	3	2
	4310-625-6752	SEAT, HIGH PRESSURE EXHAUST VALVE RE7-57A (11568)	EA		2									3	7
X1 00530	4310-616-4372	SPRING, HELICAL, COMPRESSION RE7-60 (11568)	EA		2									3	5

(1) SMR CODE INDEX NO.	(2) FEDERAL STOCK NUMBER	(3) DESCRIPTION	(4) USABLE ON CODE UNIT OF ISSUE	(5) QTY INC IN UNIT PACK	(6) QTY INC IN UNIT	(7) 30-DAY DS MAINT ALLOWANCE (A)	(7) 21-50 (B)	(7) 51-100 (C)	(8) 30-DAY GS MAINT ALLOWANCE (A)	(8) 21-50 (B)	(8) 51-100 (C)	(9) 1-YR ALW PER 100 EQUIP CNTGCTY	(10) DEPOT MAINT ALW- PER 100 EQUIP	(11) ILLUS- TRATION (A)	(11) (B)
		REFERENCE NO. & MFR. CODE				1-20	21-50	51-100	1-20	21-50	51-100				
O 00531	5310-596-7691	WASHER, LOCK: VALVE CAGE	EA		2	*	*	*	*	*	*	*	*	3	3
P O 00532	4310-631-3397	VALVE ASSEMBLY, INLET: HIGH PRESSURE Z113 (11568) (INCLUDES COMPONENTS OF GASKET SET, STOCK NO. 5330-584-9000)	EA		1	*	*	*	*	*	*	5	100	3	13
X1 00533		CAGE, INTAKE VALVE: HIGH AND LOW PRESSURE RE7-52A (11568)	EA		2									3	12
X1 00534	5310-625-6755	DISK, HIGH PRESSURE INTAKE ADN EXHAUST VALVE RE10-62 (11568)	EA		2									3	6
X2 O 00535		SCREW, MACHINE: VALVE CAGE, CADMIUM OR ZINC PLATED, NO. 10-32 THD SIZE, 3/8 IN. LG RE7-81 (11568)	EA		2									3	2
X1 00536	4310-625-6754	SEAT, HIGH PRESSURE INTAKE VALVE RE7-56A (11568)	EA		2									3	10
X1 00537	4310-616-4372	SPRING, HELICAL, COMPRESSION TR7-60 (11568) (USED WITH VALVE ASSEMBLY, STOCK NO. 4310-631-3397, ONLY)	EA		1									3	11
X1 00538	4310-329-8426	SPRING, INTAKE VALVE RE7-58 (11568) (USED WITH VALVE ASSEMBLY, STOCK NO. 4310-654-3590, ONLY)	EA		1									3	11
O 00539 00540	5310-596-7691	WASHER, LOCK: VALVE CAGE SCREW 5606 - LUBRICATION SYSTEM	EA		2	*	*	*	*	*	*	*	*	3	3
X2 O 00541		ADAPTER, STRAIGHT, PIPE TO TUBE: BREATHER, TUBE M408 (11568)	E EA		2									5	12
O 00542	4730-288-9930	ADAPTER, STRAIGHT, PIPE TO TUBE: BREATHER TUBE	EA		2	*	*	*	*	*	*	*	*	5	12
X2 O 00543		ADAPTER, STRAIGHT, PIPE TO TUBE: BREATHER TUBE M508 (11568)	DF EA		2									5	12
X2 C 00544	4310-899-1275	CAP, OIL FILLER: CRANKCASE SE30-17 (11568)	EA		1									1	24
X2 O 00545		CAP, OIL FILLER: CRANKCASE M459 (11568)	DEF EA		1									1	24

(1) SMR CODE INDEX NO.	(2) FEDERAL STOCK NUMBER	(3) DESCRIPTION	(4) USABLE ON CODE UNIT OF ISSUE	(5) QTY INC IN UNIT PACK	(6) QTY INC IN UNIT	(7) 30-DAY DS MAINT ALLOWANCE (A)	(7) 21-50 (B)	(7) 51-100 (C)	(8) 30-DAY GS MAINT ALLOWANCE (A)	(8) 21-50 (B)	(8) 51-100 (C)	(9) 1-YR ALW PER EQUIP CNTGNCY	(10) DEPOT MAINT ALW- PER EQUIP	(11) ILLUS- TRATION (A)	(11) ITEM NO. (B)
X1 00546	5330-584-9000	GASKET: OIL FILLER CAP SE30-18 (11568) (COMPONENT OF GASKET SET, STOCK NO. 4310-882-5057, SEE GROUP 5000)	ABC EA		1	1-20	21-50	51-100	1-20	21-50	51-100			1	23
X2 O 00547		NUT M27 (11568)	E EA		2										
M O 00548	4310-977-2549	TUBE ASSEMBLY, BREATHER UB254 (11568) MANUFACTURE FROM:	EA		1									5	13
O 00549	4730-142-1593	INVERTED NUT, TUBE COUPLING: BREATHER TUBE	EA		2	*	*	*	*	*	*	*	*		
P O 00550	4710-278-6398	TUBE, ALUMINUM (11 9/16 IN. REQUIRED)	FT						SEE	GRP	9501				
X2 O 00551		TUBE ASSEMBLY, BREATHER VB254 (11568)	F EA		1									5	13
	00552	5007 - COMPRESSOR DRIVE													
P O 00553	3030-243-7256	BELT, V MATCHED SET: ENGINE TO COMPRESSOR 4L540-2 (25472)	AF SET		1	2	4	8	2	4	8	100	100	6	11
P O 00554	3030-251-3941	BELT, V, MATCHED SET: MOTOR TO COMPRESSOR 4L580-2 (25472)	BCDE SET		1	2	4	8	2	4	8	100	100	11	1
X2 O 00555	5305-887-5666	BOLT, MACHINE: BELT GUARD MTG, 1/4-20 THD SIZE, 3/4 IN. LG	DE EA		2									14	13
O 00556	5306-225-8497	BOLT, MACHINE: COMPRESSOR BELT GUARD BRACKET MTG	BC EA		3	*	*	*	*	*	*	*	*	14	13
X2 O 00557		BRACKET: BELT GUARD MTG M501A (11568)	BCE EA		2									14	8
X2 O 00558	4310-065-9622	BRACKET: BELT GUARD MTG M501B (11568)	BC EA		1									14	2
X2 O 00559		BRACKET, TOP M501D (11568)	E EA		1									14	8
X2 O 00560	4310-860-0035	FLYWHEEL, COMPRESSOR NR4-7 (11568)	CDE EA		1									1	2

(1) SMR CODE INDEX NO.	(2) FEDERAL STOCK NUMBER	(3) DESCRIPTION REFERENCE NO. & MFR. CODE	(4) USABLE ON CODE UNIT OF ISSUE	(5) QTY INC IN UNIT PACK	(6) QTY INC IN UNIT	(7) 30-DAY DS MAINT ALLOWANCE (A)	(8) 30-DAY GS MAINT ALLOWANCE (B)	(9) 1-YR ALW PER EQUIP CNTGNCY	(10) 1-YR DEPOT MAINT ALW- PER EQUIP	(11) ILLUS- TRATION (A)	(B) (B) ITEM NO.		
X2 O 00561	4310-838-9846	FLYWHEEL: COMPRESSOR DRIVE NR4-7L (11568)	AF EA		1	1-20	21-50	51-100	1-20	21-50	51-100	14	2
X2 O 00562		FLYWHEEL: COMPRESSOR DRIVE NR47 (11568)	B EA		1							14	2
X2 O 00563		GUARD, BELT AND FLYWHEEL M501L (11568)	AF EA		1							14	1
X2 O 00564		GUARD, BELT AND FLYWHEEL J501 (11568)	D EA		1							14	3
X2 O 00565		GUARD, BELT: COMPRESSOR M501 (11568)	BCE EA		1							14	3
X2 O 00566		NUT 5-16N (11568)	E EA		3							14	6
O 00567	5310-543-2629	NUT, PLAIN, HEXAGON: COMPRESSOR BELT GUARD BRACKET MTG	BC EA		3	*	*	*	*	*	*	14	6
O 00568	5310-584-5005	NUT, PLAIN, HEXAGON: COMPRESSOR BELT GUARD MTG	EA		2	*	*	*	*	*	*	14	10
X2 O 00569		NUT, PLAIN, HEXAGON: FLYWHEEL TO COMPRESSOR CRANKSHAFT NR4-105 (94834)	EA		1							1	1
O 00570	5310-050-3267	NUT, SELF-LOCKING: BELT GUARD MTG	F EA		2	*	*	*	*	*	*		
O 00571	5305-225-3839	SCREW, CAP, HEXAGON HEAD: COMPRESSOR BELT GUARDS MTG	EA		2	*	*	*	*	*	*	14	4
X2 O 00572	5310-194-1540	WASHER: BELT GUARD MTG 1-4FW (79807)	D EA		2							14	9
X2 O 00573		WASHER, FLAT 5-16W (11568)	E EA		3							14	5
X2 O 00574		WASHER, FLAT: BELT GUARD MTG 1-4W (79807)	EF EA		2							14	7
X2 O 00575	5310-014-7697	WASHER, FLAT: COMPRESSOR BELT GUARD BRACKET MTG, 0.312 IN. ID, 0.875 IN. OD, 0.062 IN. THK	BC EA		3							14	7
O 00576	5310-809-4058	WASHER, FLAT: COMPRESSOR BELT GUARD MTG	EA		2	*	*	*	*	*	*	14	5

(1) SMR CODE INDEX NO.	(2) FEDERAL STOCK NUMBER	(3) DESCRIPTION	(4) USABLE ON CODE UNIT OF ISSUE	(5) QTY INC IN UNIT PACK	(6) QTY INC IN UNIT	(7) 30-DAY DS MAINT ALLOWANCE (A)	(8) 30-DAY GS MAINT ALLOWANCE (A)	(9) 1-YR ALW PER 100 EQUIP CNTGNCY	(10) DEPOT MAINT ALW- PER 100 EQUIP	(11) ILLUS- TRATION (A)	(B) (B) ITEM NO.		
X2 O 00577		REFERENCE NO. & MFR. CODE WASHER, LOCK 1-4LW (79807)	E EA		2	1-20	21-50	51-100	1-20	21-50	51-100	14	9
X2 O 00578		WASHER, LOCK 5-166W (11568)	E EA		3							14	9
X2 O 00579	5310-012-1753	WASHER, LOCK: BELT GUARD MTG 1-4ETL (79807)	D EA		2							14	7
O 00580 00851	5310-011-4604	WASHER, LOCK: COMPRESSOR BELT GUARDS MTG 5008 - AIR INTAKE	EA		2	*	*	*	*	*	*	14	9
X2 O 00582	4310-837-1359	FILTER ASSEMBLY, AIR Z64L (11568)	A EA		1							10	
X2 O 00583		BOLT, MACHINE: FILTER ASSEMBLY THRU BELT, 10-24 THD SIZE, 4 1/2 IN. LG W/ SQUARE NUT M363 (11568)	EA		1							10	4
X1 00584		CLAMP: FILTER COVER ASSEMBLY, UPPER M52 (11568)	EA		1							10	7
X1 00585	4310-993-4188	COVER: FILTER ASSEMBLY, LOWER M30 (11568)	EA		1							10	3
X1 00586		COVER: FILTER ASSEMBLY, LOWER M30L (11568) (USED WITH FILTER ASSEMBLY, STOCK NO. (11568) Z64A, ONLY)	EA		1							10	3
X1 00587	4310-993-4198	COVER: FILTER, ASSEMBLY, UPPER M31 (11568)	EA		1							10	6
X1 00588		COVER: FILTER ASSEMBLY, UPPER M31L (11568) (USED WITH FILTER ASSEMBLY, STOCK NO (11568) Z64A, ONLY)	EA		1							10	6
X2 O 00589	4310-890-0140	ELEMENT: FILTER M632 (11568)	EA		1							10	2
X1 00590	4310-999-6411	PLATE: FILTER BODY M54BL (11568)	EA		1							10	5

(1) SMR CODE INDEX NO.	(2) FEDERAL STOCK NUMBER	(3) DESCRIPTION REFERENCE NO. & MFR. CODE	(4) USABLE ON CODE UNIT OF ISSUE	(5) QTY INC IN UNIT PACK	(6) QTY INC IN UNIT	(7) 30-DAY DS MAINT ALLOWANCE (A)	(8) 30-DAY GS MAINT ALLOWANCE (A)	(9) 1-YR ALW PER EQUIP CNTGNCY	(10) DEPOT MAINT ALW- PER EQUIP	(11) ILLUS- TRATION (A)	(B) (B) ITEM NO.		
X1 00591		PLATE: FILTER BODY M54B (11568)	EA		1	1-20	21-50	51-100	1-20	21-50	51-100	10	5
X1 00592		SCREEN: FILTER ELEMENT CORE M633 (11568)	EA		1							10	1
X1 00593		SEPARATOR: FILTER ASSEMBLY M62 (11568) (USED WITH FILTER ASSEMBLY, STOCK NO. (11568) Z64A, ONLY)	EA		1								
X2 0 00594		FILTER ASSEMBLY, AIR Z64A (11568) (SAME AS FILTER ASSEMBLY, STOCK NO. 4310-837-1359 EXCEPT WHERE INDIVIDUAL COMPONENTS ARE ANNOTATED)	BCDEF	EA	1							10	
X1 00595		FERRULE: FILTER ASSEMBLY M32 (11568) (USED WITH FILTER ASSEMBLY, STOCK NO. (11568) Z64A, ONLY)	EA		1								
X2 0 00596	4310-934-8196	MANIFOLD: LOW PRESSURE INTKE, AIR COMPRESSOR SE5-2ABL (11568)	AF	EA	1							5	10
X2 0 00597		MANIFOLD: LOW PRESSURE INTAKE, AIR COMPRESSOR SE5-2AB (11568)	BCDE	EA	1							5	10
X2 0 00598		NUT, PLAIN, HEXAGON: MANIFORLDS MTG, 3/8-24 THD SIZE M462 (11568)		EA	2							5	9
0 00599 00600	5305-010-2705	SETSCREW: AIR FILTER TO LOW PRESSURE INTAKE MANIFOLDS MTG 5009 - UNLOADER SYSTEM COMPONENTS		EA	1	*	*	*	*	*	*	5	7
X1 00601	3110-606-8365	BALL, BEARING: RELIEF VALVE SE5-95 (11568) (COMPONENT OF KIT, VALVE ASSEMBLY, STOCK NO. 4310-887-2622, SEE GROUP 5000)	E	EA	1							4	3
X1 00602	4310-625-6749	BODY, RELEASE VALVE SE30-101 (11568) (COMPONENT OF KIT, VALVE ASSEMBLY, STOCK NO. 4310-887-2622, SEE GROUP 5000)	E	EA	1							4	4

(1) SMR CODE INDEX NO.	(2) FEDERAL STOCK NUMBER	(3) DESCRIPTION	(4) USABLE ON CODE UNIT OF ISSUE	(5) QTY INC IN UNIT PACK	(6) QTY INC IN UNIT	(7) 30-DAY DS MAINT ALLOWANCE (A)	(8) 30-DAY GS MAINT ALLOWANCE (A)	(9) 1-YR ALW PER 100 EQUIP CNTGNCY	(10) DEPOT MAINT ALW- PER 100 EQUIP	(11) ILLUS- TRATION (A)	(B) (B) ITEM NO.		
X2 0 00603	4310-896-5984	BREATHER: GOVERNOR HOUSING Z60A (11568)	EA		1	1-20	21-50	51-100	1-20	21-50	51-100	4	21
X1 00604		CAP, RELIEF VALVE SE5-85 (11568) (COMPONENT OF KIT, VALVE ASSEMBLY, STOCK NO. 4310-887-2622, SEE GROUP 5000)	E EA		1							4	1
X2 0 00605		COVER, GOVERNOR HOUSING: AIR COMPRESSOR RE10-100L (11568)	AF EA		1							4	20
X2 0 00606	4310-884-4518	COVER, GOVERNOR HOUSING: AIR COMPRESSOR RE10-100 (11568)	BCDE EA		1							4	20
X2 0 00607		ELBOW, PIPE TO TUBE: ELBOW, HIGH PRESSURE EXHAUST MANIFOLD TO GOVERNOR LINE, BRASS, ONE END MALE, 1/8-27 THD SIZE, OTHER END FEMALE, 1/4 IN. TUBE, 7/16-24 THD SIZE 15-4A (87005)	EA		2							5	18
X1 00608	4310-585-4283	GASKET: GOVERNOR HOUSING COVER SE14-89 (11568) (COMPONENT OF GASKET SET, STOCK NO. 4310-066-4206, AND GASKET SET, STOCK NO. 4310-882-5057, SEE GROUP 5000)	EA		1							14	19
X1 00609		GASKET: GOVERNOR UNLOADER SPRING SE5-88 (11568) (COMPONENT OF GASKET SET, STOCK NO. 4310-066-4206, SEE GROUP 5000)	DEF EA		1								
X1 00610	5330-298-5554	GASKET: RELEASE VALVE BODY M122 (11568) (COMPONENT OF KIT, VALVE ASSEMBLY, STOCK NO. 4310-887-2622, SEE GROUP 5000)	E EA		1							4	5
X1 00611	4310-633-6114	GASKET: SHIM, GOVERNOR HOUSING SE14-30A (11568) (COMPONENT OF GASKET SET, STOCK NO. 4310-066-4206 AND GASKET SET, STOCK NO. 4310-882-5057, SEE GROUP 5000)	EA		1							4	9
X2 0 00612	4310-884-4582	GUIDE, SPRING: GOVERNOR SE5-87 (11568)	EA		1							4	16

(1) SMR CODE INDEX NO.	(2) FEDERAL STOCK NUMBER	(3) DESCRIPTION	(4) USABLE ON CODE UNIT OF ISSUE	(5) QTY INC IN UNIT PACK	(6) QTY INC IN UNIT	(7) 30-DAY DS MAINT ALLOWANCE (A) (B) (C)	(8) 30-DAY GS MAINT ALLOWANCE (A) (B) (C)	(9) 1-YR ALW PER 100 EQUIP CNTGNCY	(10) DEPOT MAINT ALW- PER 100 EQUIP	(11) ILLUS- TRATION (A) (B) FIG NO. ITEM NO.			
X2 0 00613		HOUSING, GOVERNOR: AIR COMPRESSOR RE4-80AL (11568)	A EA		1					4 8			
X2 0 00614		HOUSING, GOVERNOR: AIR COMPRESSOR NR4-80BL (11568)	F EA		1					4 8			
X2 0 00615		HOUSING, GOVERNOR: AIR COMPRESSOR NR4-80B (11568)	DE EA		1					4 8			
X2 0 00616		HOUSING, GOVERNOR: AIR COMPRESSOR RE-80A (11568)	BC EA		1					4 8			
M O 00617	4310-986-9683	LINE ASSEMBLY: HIGH PRESSURE EXHAUST MANIFOLD TO GOVERNOR SB254 (11568) MANUFACTURE FROM:	EA		1					5 19			
O 00618	4730-142-1593	INVERTED NUT, TUBE COUPLING: HIGH PRESSURE EXHAUST MANIFOLD TO GOVERNOR LINE	EA		2	*	*	*	*	*			
P O 00619 M O 00620	4710-277-5525	TUBE, COPPER (24 IN. REQUIRED) LINE ASSEMBLY: HIGH PRESSURE EXHAUST MANIFOLD TO GOVERNOR UB254 (11568) MANUFACTURE FROM:	FT EA F				SEE	GRP	9501	5 19			
X2 0 00621	4730-289-1959	INVERTED NUT, TUBE COUPLING 11-14 (87005)	F EA		2								
P O 00622	4710-277-5525	TUBE, COPPER (24 IN. REQUIRED)	F FT				SEE	GRP	9501				
X2 0 00623	4310-977-2549	LINE ASSEMBLY: HIGH PRESSURE EXHAUST MANIFOLD TO GOVERNOR SE254 (11568)	E EA		1					5 19			
X1 00624		INVERTED NUT, TUBE COUPLING: HIGH PRESSURE MANIFOLD TO GOVERNOR LINE M27 (11568)	E EA		2								
P O 00625	4310-877-2622	PARTS KIT, RELIEF VALVE: UNLOADER, GOVERNOR, RELEASE Z124-150 (11568)	EA		1	2	2	3	2	2	3	30	100
X1 00626	3110-606-8365	BALL, BEARING: RELIEF VALVE, 1/4 IN. DIA SE5-95 (11568)	EA		1						4	3	

(1) SMR CODE INDEX NO.	(2) FEDERAL STOCK NUMBER	(3) DESCRIPTION REFERENCE NO. & MFR. CODE	(4) USABLE ON CODE UNIT OF ISSUE	(5) QTY INC IN UNIT PACK	(6) QTY INC IN UNIT	(7) 30-DAY DS MAINT ALLOWANCE (A)	(8) 30-DAY GS MAINT ALLOWANCE (B)	(9) 1-YR ALW PER EQUIP CNTGNCY	(10) DEPOT MAINT ALW- PER EQUIP	(11) ILLUS- TRATION (A)	(B) (B) ITEM NO.		
X1 00627	4310-625-6749	BODY, RELEASE VALVE SE30-101 (11568)	EA		1	1-20	21-50	51-100	1-20	21-50	51-100	4	4
X1 00628		CAP, RELIEF VALVE SE5-85 (11568)	EA		1							4	1
X1 00629	5330-298-5554	GASKET: RELEASE VALVE BODY 2030 (79150)	EA		1							4	5
X1 00630	4310-654-3589	PLUNGER, RELIEF VALVE SE5-86A (11568)	EA		1							4	18
X1 00631	4310-625-6748	SLEEVE, PLUNGER: RELIEF VALVE SE5-97 (11568)	EA		1							4	6
X1 00632	4310-616-4373	SPRING, RELIEF VALVE SE5-91 (11568)	EA		1							4	2
0 00633	5315-846-4881	PIN, STRAIGHT, HEADLESS: GOVERNOR	EA		2	*	*	*	*	*	*	4	25
X2 0 00634		PIN, STRAIGHT, HEADLESS: GOVERNOR, 0.312 IN. DIA, 1.937 IN. LG SE5-92A (11568)	DF EA		2							4	25
X2 0 00635		PLATE, BAFFLE, UNLOADER: GOVERNOR RE14-104 (11568)	EA		1							4	7
X2 0 00636		PLATE, BAFFLE, UNLOADER: GOVERNOR NR104 (11568)	E EA		1							4	7
X1 00637	4310-654-3589	PLUNGER, RELIEF VALVE SE5-86A (11568) (COMPONENT OF KIT, VALVE ASSEMBLY, STOCK NO. 4310-887-2622, SEE GROUP 5000)	E EA		1							4	18
X2 0 00638	5305-261-1868	SCREW, CAP, HEXAGON HEAD: GOVERNOR HOUSING MTG M472 (11568)	E EA		4							4	10
X2 0 00639		SCREW, CAP, HEXAGON HEAD: GOVERNOR HOUSING MTG, 3/8-16 THD SIZE, 1 IN. LG RE20-106 (11568)	EA		4							4	10

(1) SMR CODE INDEX NO.	(2) FEDERAL STOCK NUMBER	(3) DESCRIPTION	(4) USABLE ON CODE UNIT OF ISSUE	(5) QTY INC IN UNIT PACK	(6) QTY INC IN UNIT	(7) 30-DAY DS MAINT ALLOWANCE (A)	(8) 30-DAY GS MAINT ALLOWANCE (B)	(9) 1-YR ALW PER EQUIP CNTGNCY	(10) DEPOT MAINT ALW- PER EQUIP	(11) ILLUS- TRATION (A)	(12) (B)		
X2 0 00640		REFERENCE NO. & MFR. CODE SCREW, CAP, HEXAGON HEAD: GOVERNOR SPINDLE 7/16-20 THD SIZE, 1 IN. LG SE5-94 (11568)	EA		1	1-20	21-50	51-100	1-20	21-50	51-100	4	13
X2 0 00641		SCREW, MACHINE: GOVERNOR COVER HOUSING MTG, NO. 10-32 THD SIZE, 5/8 IN. LG SE14-84 (11568)	EA		6							4	22
X1 00642	4310-625-6748	SLEEVE, PLUGHER: RELIEF VALVE SE5-97 (11568) (COMPONENT OF KIT, VALVE ASSEMBLY, STOCK NO. 4310-887-2622, SEE GROUP 5000)	E EA		1							4	6
X2 0 00643	2990-863-0926	SPINDLE, GOVERNOR: UNLOADER SE5-83B (11568)	EA		1							4	11
X2 0 00644	4310-896-2104	SPRING, HELICAL, COMPRESSION: GOVERNOR H110P (11568)	EA		2							4	23
X1 00645	4310-616-4373	SPRING, RELIEF VALVE SE5-91 (11568) (COMPONENT OF KIT, VALVE ASSEMBLY, STOCK NO. 4310-887-2622, SEE GROUP 5000)	E EA		1							4	2
X2 0 00646	4310-850-5541	SPRING, UNLOADER: GOVERNOR SE5-90 (11568)	EA		1							4	15
X2 0 00647		VALVE, SAFETY: RELIEF EXHAUST MANIFOLD, 200 PSI Z206-200 (75336)	E EA		1							5	4
X2 0 00648		VALVE, SAFETY: RELIEF, EXHAUST MANIFOLD, 200 PSI, 1/4-18 THD SIZE FIG112-200 (75336)	ABD EA		1							5	4
X2 0 00649		VALVE, SAFETY: RELIEF, EXHAUST MANIFOLD, 200 PSI, 1/4-18 THD SIZE FIG112-1-4-200 (75336)	F EA		1							5	4
X2 0 00650		VALVE, SAFETY: RELIEF, HIGH PRESSURE MANIFOLDS, INTERCOOLER TUBES FIG125-70 (75336)	EA D		1							5	8

(1) SMR CODE INDEX NO.	(2) FEDERAL STOCK NUMBER	(3) DESCRIPTION	(4) USABLE ON CODE UNIT OF ISSUE	(5) QTY INC IN UNIT PACK	(6) QTY INC IN UNIT	(7) 30-DAY DS MAINT ALLOWANCE (A)	(8) 30-DAY GS MAINT ALLOWANCE (A)	(9) 1-YR ALW PER EQUIP CNTGNCY	(10) DEPOT MAINT ALW- EQUIP	(11) ILLUS- TRATION (A)	(B) ITEM NO.
X2 0 00651		VALVE, SAFETY: RELIEF, HIGH PRESSURE MANIFOLDS, INTERCOOLER TUBES, 70 PSI Z67-70 (75336)	E EA		1	1-20 21-50 51-100	1-20 21-50 51-100		5	8	
X2 0 00652		VALVE, SAFETY RELIEF: HIGH PRESSURE MANIFOLDS INTERCOOLER TUBES, 75 PSI, 1/4-18 THD SIZE FIG125-1-4-75LB (75336)	EA		1				5	8	
X2 0 00653		WASHER, FLAT: GOVERNOR UNLOADER SPRING, 3/8 IN. ID, 7/8 IN. OD, 0.083 IN. THK SE5-88 (11568)	EA		1				4	14	
X2 0 00654		WASHER, LOCK: GOVERNOR SPINDLE SCREW, 0.446 IN. ID, 0.784 IN. OD, 0.0109 IN. THK M466 (11568)	EA		1				4	12	
X2 0 00655	4310-896-2105	WEIGHT, GOVERNOR: UNLOADER SE5-82 (11568)	EA		2				4	17	
X2 0 00656		WEIGHT, GOVERNOR: UNLOADER SE5-82A (11568)	E EA		2				4	17	
X2 0 00657		WIRE, LOCK: GOVERNOR WEIGHT PINS SE5-98 (11568)	EA		1				4	24	
00658		5010 - COMPRESSOR COOLING									
X2 0 00659		FITTING, COMPRESSION: EXHAUST AND AFTERCOOLER TUBE TO AIR RECEIVERS, STEEL, 3/4-14 THD SIZE, MALE, 1/16 THD SIZE FEMALE, FOR 3/4 IN. TUBE RE10-99 (11568)	EA		1				5	14	
0 00660	4730-850-7971	INVERTED NUT, TUBE COUPLING: EXHAUST, AFTERCOOLER, AND INTERCOOLER TUBES TO AIR RECEIVERS AND MANIFOLDS	EA		4	* * *	* * *	* * *	5	2	
X2 0 00661		MANIFOLD: HIGH PRESSURE EXHAUST NR2BL (11568)	F EA		1				5	5	
X2 0 00662		MANIFOLD: HIGH PRESSURE EXHAUST, AIR COMPRESSOR NR2B (11568)	DE EA		1				5	5	
X2 0 00663	4310-075-1685	MANIFOLD: HIGH PRESSURE EXHAUST, AIR COMPRESSOR NR2ABL (11568)	A EA		1				5	5	

(1) SMR CODE INDEX NO.	(2) FEDERAL STOCK NUMBER	(3) DESCRIPTION	(4) USABLE ON CODE UNIT OF ISSUE	(5) QTY INC IN UNIT PACK	(6) QTY INC IN UNIT	(7) 30-DAY DS MAINT ALLOWANCE (A)	(8) 30-DAY GS MAINT ALLOWANCE (B)	(9) 1-YR ALW PER EQUIP CNTGNCY	(10) 1-YR DEPOT MAINT ALW- PER EQUIP	(11) ILLUS- TRATION (A)	(B) (B) ITEM NO.			
		REFERENCE NO. & MFR. CODE				1-20	21-50	51-100	1-20	21-50	51-100	FIG NO.	ITEM NO.	
X2 0 00664	4310-961-3667	MANIFOLD: HIGH PRESSURE EXHAUST, AIR COMPRESSOR NR2AB (11568)	BC EA		1							5	5	
X2 0 00665		MANIFOLD: HIGH PRESSURE INTAKE SE5-2CL (11568)	F EA		1							5	6	
X2 0 00666		MANIFOLD: HIGH PRESSURE INTAKE, AIR COMPRESSOR SE5-2C1 (11568)	A EA		1							5	6	
X2 0 00667		MANIFOLD: HIGH PRESSURE INTAKE, AIR COMPRESSOR SE5-2C (11568)	DE EA		1							5	6	
X2 0 00668	2815-928-6078	MANIFOLD: HIGH PRESSURE INTAKE, AIR COMPRESSOR SE5-2A (11568)	BC EA		1							5	6	
X2 0 00669		MANIFOLD: LOW PRESSURE EXHAUST, AIR COMPRESSOR NR2L (11568)	AF EA		1							5	21	
X2 0 00670	4310-961-3666	MANIFOLD: LOW PRESSURE EXHAUST, AIR COMPRESSOR NR2 (11568)	BCDE EA		1							5	21	
X2 0 00671 0 00672	5310-265-9215 4730-851-6259	NUT, PLAIN, HEXAGON: MANIFOLDS MTG SLEEVE, COMPRESSION, TUBE-HOSE FITTING: EXHAUST, AFTERCOOLER, AND INTERCOOLER TUBE TO AIR RECEIVERS AND MANIFOLDS	EA EA		6 4		*	*	*	*	*	*	5 5	9 3
X2 0 00673		TUBE, AFTERCOOLER: AIR COMPRESSOR TO AIR RECEIVER NR4-1H (11568)	BC EA		1							5	20	
M O 00674		TUBE, EXHAUST: AIR COMPRESSOR TO AIR RECEIVER, COPPER, 3/4 IN. OD, 19 IN. LG NR4-1P (11568) MANUFACTURE FROM:	AF EA		1							5	20	
P O 00675 X2 0 00676	4710-277-7748	TUBE, COPPER (19 IN. REQUIRED) TUBE, EXHAUST: AIR COMPRESSOR TO AIR RECEIVER, 3/4 IN. OD, 19 IN. LG NR4-1H (11568)	AF FT DE EA					SEE	GRP*9501				5 1	1
X2 0 00677		TUBE, INTERCOOLER: LOW TO HIGH PRESSURE CYLINDERS RE12 (11568)	F EA		1							5	1	

(1) SMR CODE INDEX NO.	(2) FEDERAL STOCK NUMBER	(3) DESCRIPTION REFERENCE NO. & MFR. CODE	(4) USABLE ON CODE UNIT OF ISSUE	(5) QTY INC IN UNIT PACK	(6) QTY INC IN UNIT	(7) 30-DAY DS MAINT ALLOWANCE (A) (B) (C)	(8) 30-DAY GS MAINT ALLOWANCE (A) (B) (C)	(9) 1-YR ALW PER 100 EQUIP CNTGNCY	(10) DEPOT MAINT ALW- PER 100 EQUIP	(11) ILLUS- TRATION (A) (B)	FIG NO.	ITEM NO.
X2 0 00678	4310-977-8670	TUBE, INTERCOOLER: LOW TO HIGH PRESSURE CYLINDERS RE4-12A (11568)	EA		1						5	1
X2 0 00679		TUBE, INTERCOOLER: LOW TO HIGH PRESSURE CYLINDERS RE4-12 (11568)	DE EA		1						5	20
00680		5014 - AIR RECEIVER										
0 00681	5306-225-8503	BOLT, MACHINE: AIR RECEIVER MTG	A EA		1	*	*	*	*	*	7	22
X2 0 00682	5306-021-5371	BOLT, MACHINE: AIR RECEIVER MTG, 5-16-18 THD SIZE, 2 IN. LG	A EA		1						7	17
0 00683	5306-010-8503	BOLT, MACHINE: RECEIVER MTG	EA		2	*	*	*	*	*	7	22
0 00684	4730-684-4648	BUSHING, PIPE: SAFETY VALVE TO RECEIVER	BC EA		1	*	*	*	*	*	15	1
X2 0 00685	4310-874-3181	COCK, DRAIN: AIR RECEIVER M629 (11568)	DE EA		1						15	12
X2 0 00686	4310-874-3181	COCK, DRAIN: AIR RECEIVER 1825A (92976)	EA		1						15	12
X2 0 00687	4310-874-3181	COCK, DRAIN: AIR RECEIVER, BRASS, 1/4-18 THD SIZE, MALE 1825A (92976)	EA		1						7	19
0 00688	4730-257-5028	ELBOW, PIPE: CHECK VALVE TO RECEIVER TEE	BCD EA		1	*	*	*	*	*	5	15
X2 0 00689		ELBOW, PIPE: STREET, CHECK VALVE TO RECEIVER PF1205D (14959)	EA		1						5	15
X2 0 00690		NIPPLE 1-2X1-5 (11568)	E EA		1							
0 00691	4730-277-9657	NIPPLE, PIPE: CHECK AND SAFETY VALVE, TEE TO RECEIVER	BCDE EA		1	*	*	*	*	*	15	3
0 00692	4730-277-9659	NIPPLE, PIPE: CHECK VALVE TO TEE, AIR RECEIVER	BC EA		1	*	*	*	*	*	5	17
X2 0 00693		NUT, SELF-LOCKING, HEXAGON: AIR RECEIVER MTG, 5/16-18 THD SIZE 29NE058 (11568)	AF EA		2						7	28

(1) SMR CODE INDEX NO.	(2) FEDERAL STOCK NUMBER	(3) DESCRIPTION REFERENCE NO. & MFR. CODE	(4) USABLE ON CODE UNIT OF ISSUE		(5) QTY INC IN UNIT PACK	(6) QTY INC IN UNIT	(7) 30-DAY DS MAINT ALLOWANCE (A) (B) (C)			(8) 30-DAY GS MAINT ALLOWANCE (A) (B) (C)			(9) 1-YR ALW PER 100 EQUIP CNTGNCY	(10) DEPOT MAINT ALW- PER 100 EQUIP	(11) ILLUS- TRATION (A) (B) FIG NO. ITEM NO.	
0 00694 X2 0 00695	4730-287-0022	PLUG, PIPE: AIR RECEIVER RECEIVER, AIR 1136H34 (11568)	BC	EA	2	*	*	*	*	*	*	*	*	15	13	
X2 0 00696		LOOP, TIE DOWN AND LIFTING MS27 (11568)	BDE	EA	1									15	5	
X2 0 00696		LOOP, TIE DOWN AND LIFTING MS27 (11568)	B	EA	4									15	14	
X2 0 00697		RECEIVER, AIR 1136G34 (86823)	C	EA	1									15	5	
X2 0 00698	4310-930-2561	RECIVER, AIR: COMPRESSOR, 200 PSI P2202B (11568)	AF	EA	1									7	18	
0 00699 X2 0 00700	4730-257-2119	TEE, PIPE: CHECK AND SAFETY VALVE TO RECEIVER TEE, PIPE: CHECK AND SAFETY VALVE TO RECEIVER 1-2T (86285)	BC	EA	1	*	*	*	*	*	*	*	*	15	2	
X2 0 00702		VALVE ASSEMBLY, CHECK Z220A (11568)	DE	EA	1									15	2	
P O 00701	4310-532-7791	VALVE ASSEMBLY, CHECK Z220A (11568)	BC	EA	1	*	*	*	*	*	*	5	5	5	16	
X2 0 00702		VALVE ASSEMBLY, CHECK Z220B (11568)	DE	EA	1									5	16	
X1 00703		BODY: CHECK VALVE M449B (11568)	DE	EA	1											
X1 00704		CAP: CHECK VALVE M450A (11568)	DE	EA	1											
X1 00705		DISK: CHECK VALVE H41P (11568)	DE	EA	1											
X1 00706	5310-020-5186	NUT, BRASS: CHECK VALVE 1-4-20N (87764)	DE	EA	1											
X1 00707		PLUNGER: CHECK VALVE M54 (11568)	DE	EA	1											
X1 00708	5305-011-3976	SCREW: CHECK VALVE, 1/4-20 THD SIZE, 5/8 IN. LG	DE	EA	1											
X1 00709	4310-875-4108	SPRING: CHECK VALVE M453A (11568)	DE	EA	1											

(1) SMR CODE INDEX NO.	(2) FEDERAL STOCK NUMBER	(3) DESCRIPTION	(4) USABLE ON CODE UNIT OF ISSUE	(5) QTY INC IN UNIT PACK	(6) QTY INC IN UNIT	(7) 30-DAY DS MAINT ALLOWANCE (A)	(7) 21-50 (B)	(7) 51-100 (C)	(8) 30-DAY GS MAINT ALLOWANCE (A)	(8) 21-50 (B)	(8) 51-100 (C)	(9) 1-YR ALW PER 100 EQUIP CNTGCTY	(10) DEPOT MAINT ALW- PER 100 EQUIP	(11) ILLUS- TRATION (A)	(11) (B) FIG NO.	(11) (B) ITEM NO.
P O 00710	4820-888-9302	VALVE, UNLOADER: AIR RECEIVER PRESSURE RELIEF FP7410 (71342)	A EA	1		*	*	*	*	*	*	5	3	7	20	
X1 00711		BODY: UNLOADER VALVE 7404 (71342)	A EA	1												
X1 00712		CAP, BODY: UNLOADER VALVE 7392 (71342)	A EA	1												
X1 00713	5330-884-0705	GASKET, CAP: UNLOADER VALVE 7396 (71342)	A EA	1												
X1 00714		SCREW, PRESSURE: UNLOADER VALVE 7394 (71342)	A EA	1												
X1 00715		SEAT, COMPOSITION: UNLOADER VALVE 6382 (71342)	A EA	1												
X1 00716		SEAT, SCREW: UNLOADER VALVE 6383 (71342)	A EA	1												
X1 00717		SEAT, SHELL: UNLOADER VALVE 6381 (71342)	A EA	1												
X1 00718		SPRING: UNLOADER VALVE 6711 (71342)	A EA	1												
P O 00719	4820-888-9302	VALVE, UNLOADER: RECEIVER PRESSURE RELIEF FP175 (71342)	F EA	1		*	*	*	*	*	*	5	3	7	20	
X2 0 00720	5310-014-7697	WASHER, FLAT: AIR RECEIVER MTG, 0.312 IN. ID, 0.875 IN. OD, 0.062 IN. THK	EA	4										7	23	
00721		5015 - AIR DISCHARGE SYSTEM														
0 00722	4730-391-3771	ADAPTER, STRAIGHT TO TUBE: AIR HOSE TO RECEIVER AND AIR CHUCK	EA	2		*	*	*	*	*	*	*	*	7	21	
0 00723	4730-391-3771	ADAPTER, STRAIGHT, PIPE TO TUBE: AIR HOSE TO RECEIVER AND INFLATOR GAGE	EA	2		*	*	*	*	*	*	*	*	15	8	
X2 0 00724		ADAPTER, STRAIGHT, PIPE TO TUBE: AIR HOSE TO RECEIVER AND INFLATOR GAGE LL2-40 (11568)	D EA	2										15	8	

(1) SMR CODE INDEX NO.	(2) FEDERAL STOCK NUMBER	(3) DESCRIPTION	(4) USABLE ON CODE UNIT OF ISSUE		(5) QTY INC IN UNIT PACK	(6) QTY INC IN UNIT	(7) 30-DAY DS MAINT ALLOWANCE			(8) 30-DAY GS MAINT ALLOWANCE			(9) 1-YR ALW PER 100 EQUIP CNTGNCY	(10) DEPOT MAINT ALW- PER 100 EQUIP	(11) ILLUS- TRATION (A) (B)	
		REFERENCE NO. & MFR. CODE					1-20	21-50	51-100	1-20	21-50	51-100			FIG NO.	ITEM NO.
X2 0 00725	4730-202-6669	NIPPLE, PIPE: BUSHING, PIPE: GLOBE VALVE M554 (11568)	E	EA		2									15	9
0 00726	4730-277-8809	BUSHING, PIPE: GLOBE VALVE	BC	EA		1	*	*	*	*	*	*	*	*	15	9
X2 0 00727	4730-202-6669	BUSHING, PIPE: GLOBE VALVE PF604B (26403)	D	EA		1									15	9
0 00728	4730-050-1717	NIPPLE, PIPE: GLOBE VALVE	BCB	EA		1	*	*	*	*	*	*	*	*	15	11
X2 0 00729		NIPPLE, PIPE: GLOBE VALVE 1-2CN (11568)	E	EA		1									15	11
X2 0 00730	4820-274-7389	VALVE, GLOBE: AIR RECEIVER HOSE, SHUT-OFF M523 (11568)	DE	EA		1									15	10
X2 0 00731		VALVE, GLOBE: AIR RECEIVER HOSE SHUT-OFF, BRASS OR BRONZE, 1/2-14 THD SIZE, 125 PSI T1014 (91895)	BC	EA		1									15	10
00732		GROUP 95 - GENERAL USE STANDARDIZED PARTS														
00733		9501 - BULK MATERIAL														
P F 00734	9510-229-0883	BAR, STEEL: 1/4 IN. DIA	C	FT		*	*	*	*	*	*	50	50			
P O 00735	5330-298-5674	CORK, SHEET: 1/16 IN. THK, 24 IN. W, 24 IN. LG	A	SH		*	*	*	*	*	*	2	2			
P O 00736	5330-262-2543	FELT, STRIP: 3 3/4 IN. W, 3/16 IN. THK, 12 9/16 IN. LG	A	FT		*	*	*	*	*	*	4	4			
P O 00737	4710-278-6398	TUBE, ALUMINUM: 1/4 IN. DIA		FT		*	*	*	*	*	*	25	25			
P O 00738	4710-277-5525	TUBE, COPPER: 0.250 IN. DIA		FT		*	*	*	*	*	*	50	50			
P O 00739	4710-277-7748	TUBE, COPPER: 0.750 IN. DIA	A	FT		*	*	*	*	*	*	36	36			
P O 00740	6145-192-2575	WIRE, ELECTRICAL: COPPER, NO. 10 AWG, 0.170 IN. DIA, SOLID CONDUCTOR	BC	FT		*	*	*	*	*	*	50	50			
P O 00741	6145-161-5415	WIRE, ELECTRICAL: COPPER, NO. 14 AWG, SOLID CONDUCTOR	BC	FT		*	*	*	*	*	*	50	50			
P O 00742	6145-160-5137	WIRE, ELECTRICAL: COPPER, TINNED FINISH, NO. 14 AWG, 19 STRANDS OF NO. 27 AWG		FT		*	*	*	*	*	*	50	50			

(1) SMR CODE INDEX NO.	(2) FEDERAL STOCK NUMBER	(3) DESCRIPTION REFERENCE NO. & MFR. CODE	(4) USABLE ON CODE UNIT OF ISSUE	(5) QTY INC IN UNIT PACK	(6) QTY INC IN UNIT	(7) 30-DAY DS MAINT ALLOWANCE (A)	(7) 21-50 (B)	(7) 51-100 (C)	(8) 30-DAY GS MAINT ALLOWANCE (A)	(8) 21-50 (B)	(8) 51-100 (C)	(9) 1-YR ALW PER EQUIP CNTG	(10) DEPOT MAINT ALW- PER EQUIP	(11) ILLUS- TRATION (A)	(11) (B)
P O 00743	8305-430-9284	WEBBING, TEXTILE: COTTON, 1/8 IN. THK, 10 IN. W, 10 IN. LG	A	FT	*	*	*	*	*	*	2	2			
00744		GROUP 99 - PARTS PECULIAR													
00745		9901 - MULTI - LISTED PARTS													
P F 00746	4310-631-9407	BEARING, SLEEVE		EA	2	*	*	2	*	*	2	10	100		
P F 00747	4310-646-9749	SHIM		EA	4	2	2	3	2	2	3	40	400		

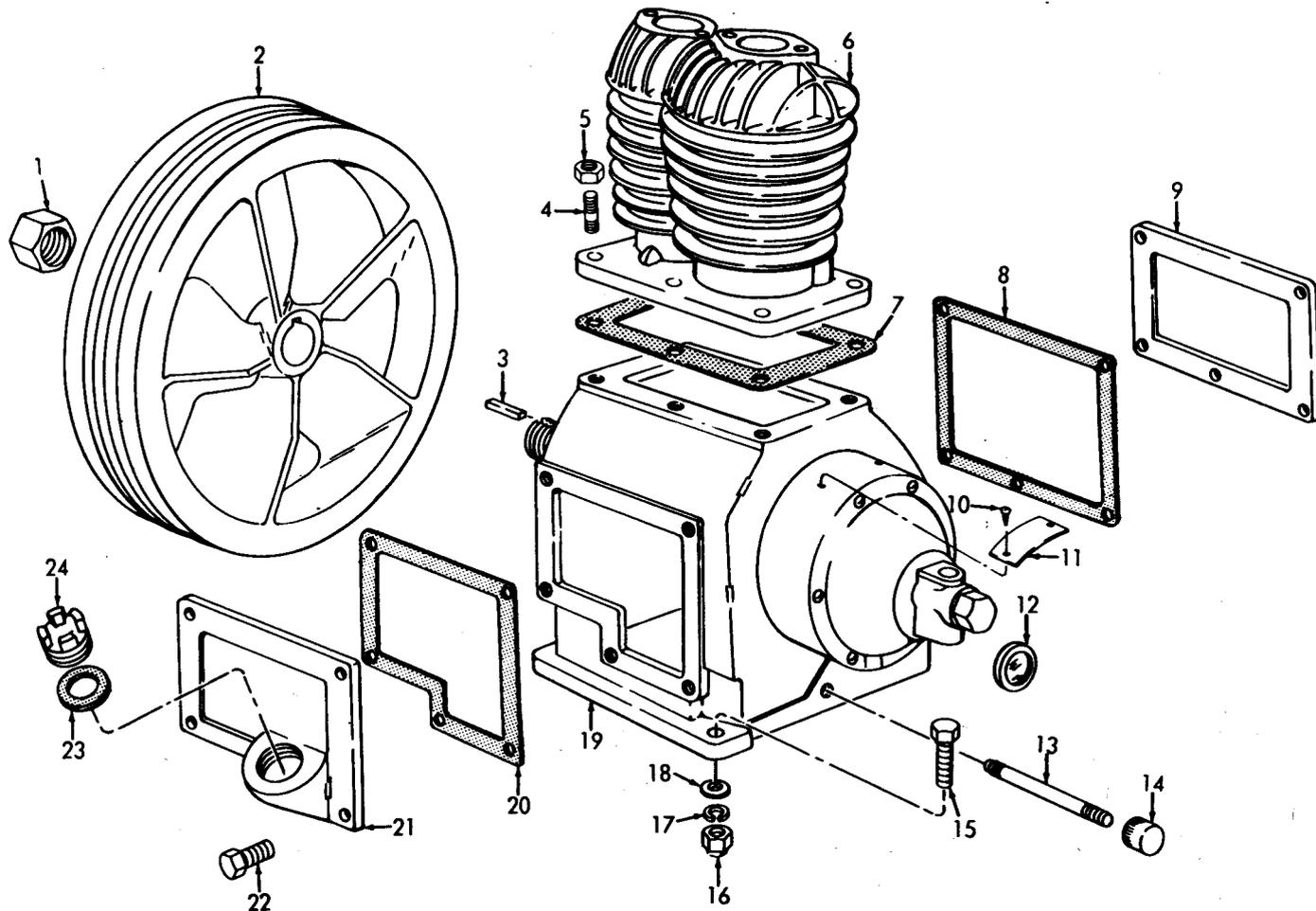

ME 4310-241-35P/1

Figure 1. Compressor, Flywheel, Oil Drain, and Related Parts.

INDEX TO PARTS, FIGURE 1

Reference Number	Functional Group	Item Name	Reference Number	Functional Group	Item Name
1	5007	NUT	13	5001	NIPPLE
2	5007	FLYWHEEL	14	5001	CAP
3	5002	KEY	15	5000	SCREW
4	5001	STUD	16	5000	NUT
5	5001	NUT	17	5000	WASHER
6	5001	BLOCK	18	5000	WASHER
7	5001	GASKET	19	5001	CRANKCASE
8	5001	GASKET	20	5001	GASKET
9	5001	PLATE	21	5001	PLATE
10	2210	SCREW	22	5001	BOLT
11	2210	PLATE	23	5006	GASKET
12	5001	WINDOW	24	5006	CAP

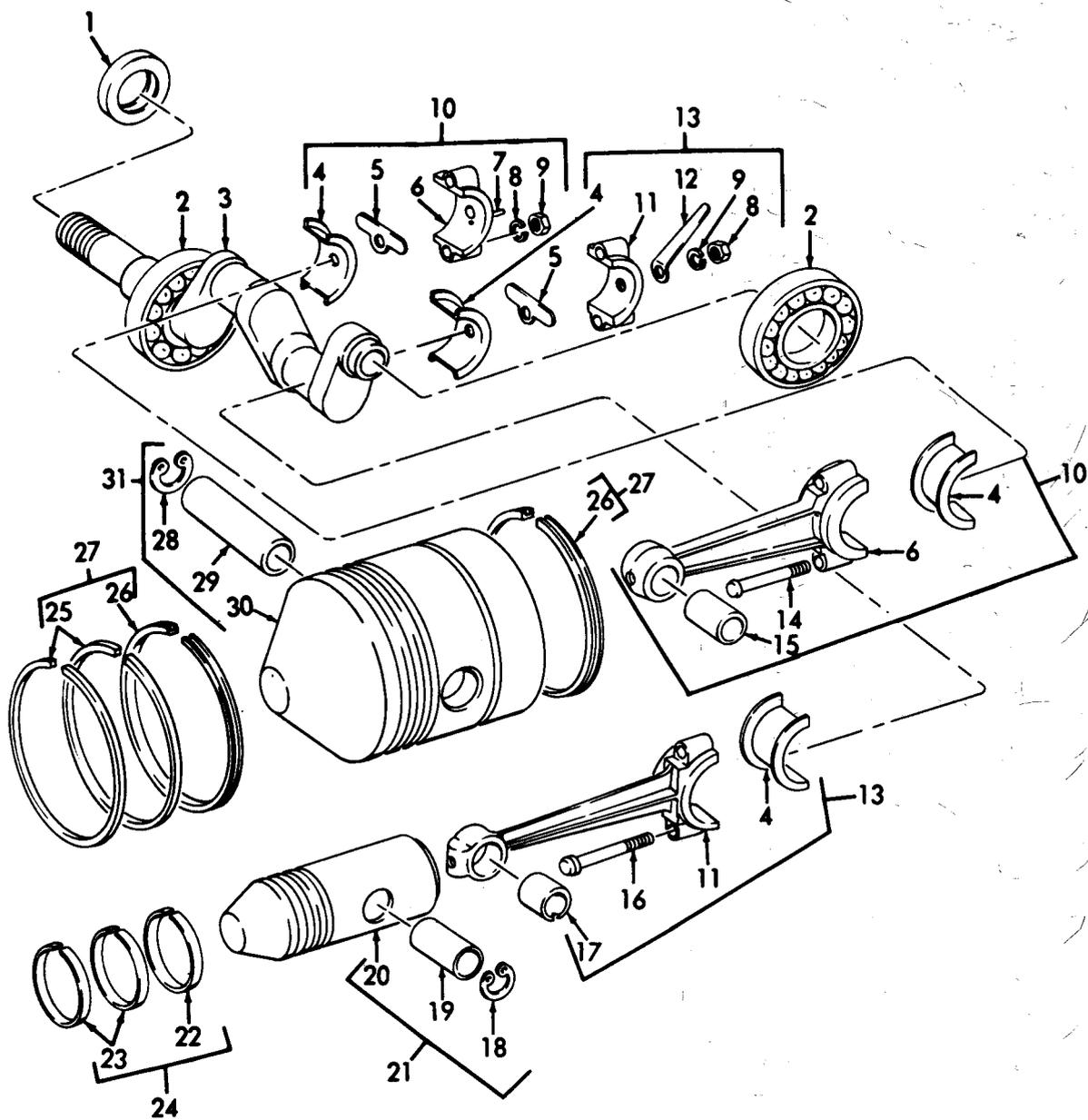

ME 4310-241-35P/2

Figure 2. Crankshaft, Bearings, Pistons, Rods, and Related Parts.

INDEX TO PARTS, FIGURE 2

Reference Number	Functional Group	Item Name	Reference Number	Functional Group	Item Name
1	5002	SEAL	17	5004	BEARING
2	5002	BEARING	18	5004	RING
3	5002	CRANKSHAFT	19	5004	PIN
4	5004	BEARING	20	5004	PISTON
5	5004	SHIM	21	5004	PISTON AY
6	5004	ROD	22	5004	RING
7	5004	PIN	23	5004	RING
8	5004	WASHER	24	5004	RING SET
9	5004	NUT	25	5004	RING
10	5004	ROD AY	26	5004	RING
11	5004	ROD	27	5004	RING SET
12	5004	SCOOP	28	5004	RING
13	5004	ROD AY	29	5004	PIN
14	5004	BOLT	30	5004	PISTON
15	5004	BEARING	31	5004	PISTON AY
16	5004	BOLT			

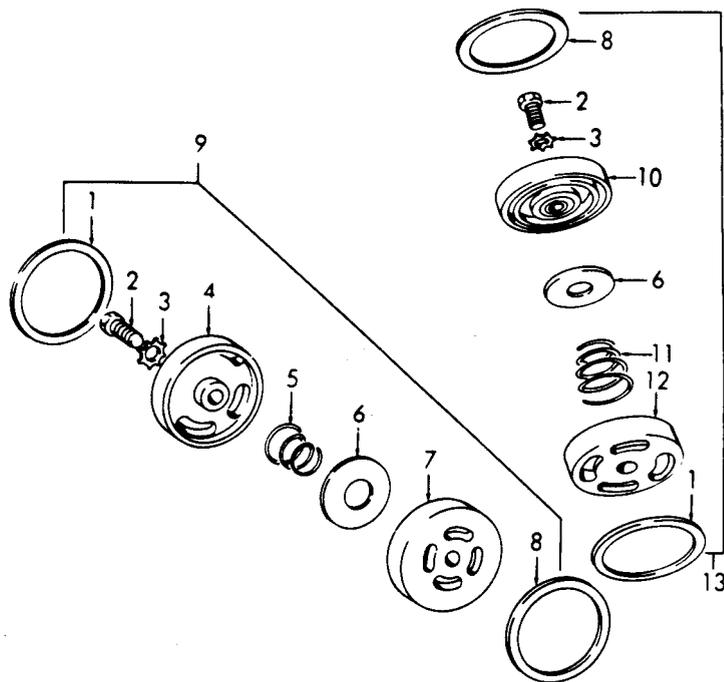

ME 4310-241-35P/3

Figure 3. High and Low Pressure Valve Assemblies.

INDEX TO PARTS, FIGURE 3

Reference Number	Functional Group	Item Name	Reference Number	Functional Group	Item Name
1	5005	GASKET	8	5005	GASKET
2	5005	SCREW	9	5005	VALVE AY
3	5005	WASHER	10	5005	SEAT
4	5005	CAGE	11	5005	SPRING
5	5005	SPRING	12	5005	CAGE
6	5005	DISK	13	5005	VALVE AY
7	5005	SEAT			

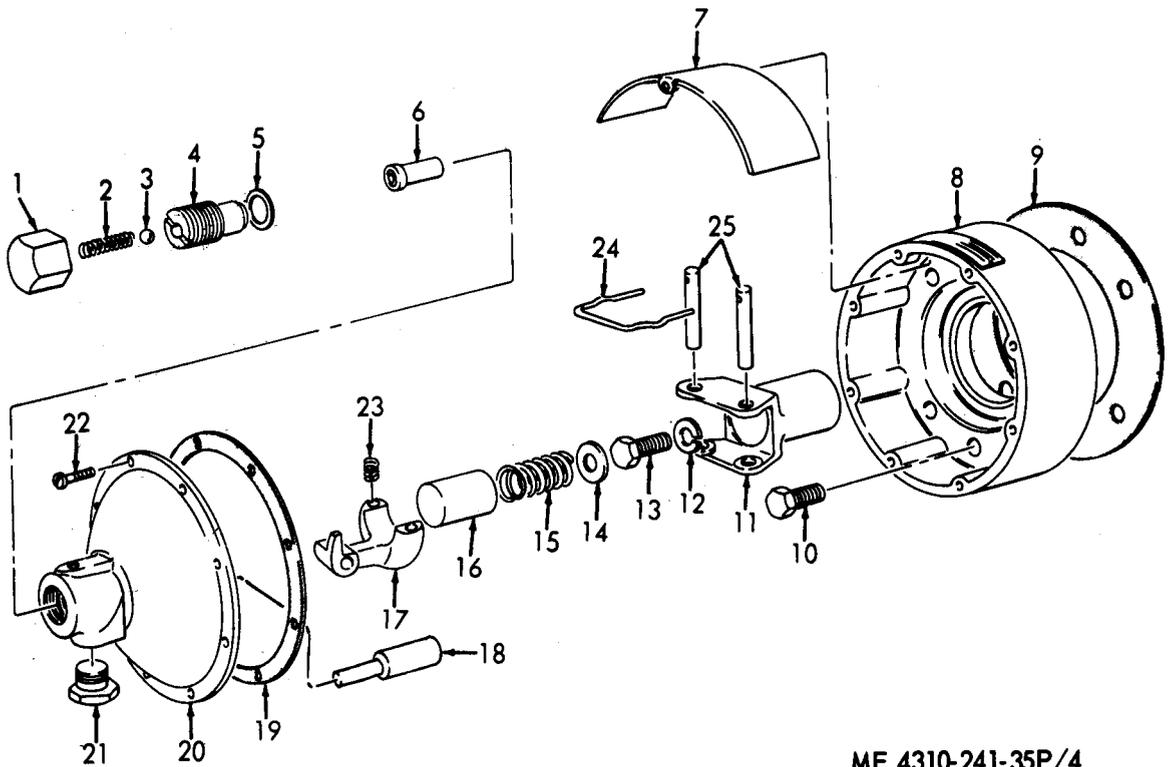

ME 4310-241-35P/4

Figure 4. Governor and Relief Valve.

INDEX TO PARTS, FIGURE 4

Reference Number	Functional Group	Item Name	Reference Number	Functional Group	Item Name
1	5009	CAP	14	5009	WASHER
2	5009	SPRING	15	5009	SPRING
3	5009	BALL	16	5009	GUIDE
4	5009	BODY	17	5009	WEIGHT
5	5009	GASKET	18	5009	PLUNGER
6	5009	SLEEVE	19	5009	GASKET
7	5009	PLATE	20	5009	COVER
8	5009	HOUSING	21	5009	BREATHER
9	5009	GASKET	22	5009	SCREW
10	5009	SCREW	23	5009	SPRING
11	5009	SPINDLE	24	5009	WIRE
12	5009	WASHER	25	5009	PIN
13	5009	SCREW			

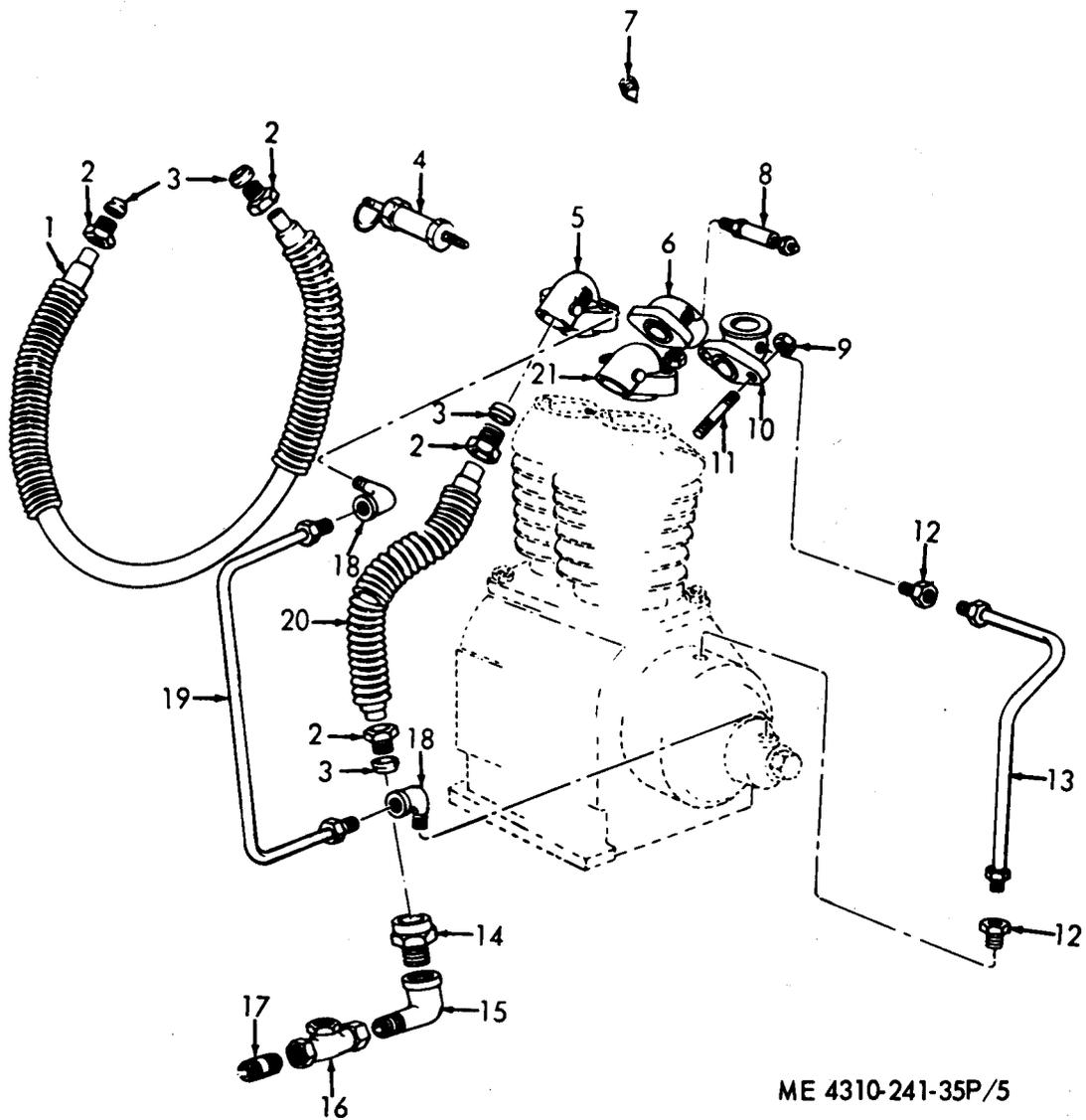

ME 4310-241-35P/5

Figure 5. Manifolds, Valves, Tubes, and Fittings.

INDEX TO PARTS, FIGURE 5

Reference Number	Functional Group	Item Name	Reference Number	Functional Group	Item Name
1	5010	TUBE	11	5001	STUD
2	5010	INVERTED NUT	12	5006	ADAPTER
3	5010	SLEEVE	13	5006	TUBE AY
4	5009	VALVE	14	5010	FITTING
5	5010	MANIFOLD	15	5014	ELBOW
6	5010	MANIFOLD	16	5014	VALVE AY
7	5008	SETSCREW	17	5014	NIPPLE
8	5009	VALVE	18	5009	ELBOW
9	5008	NUT	19	5009	LINE AY
9	5010	NUT	20	5010	TUBE
10	5008	MANIFOLD	21	5010	MANIFOLD

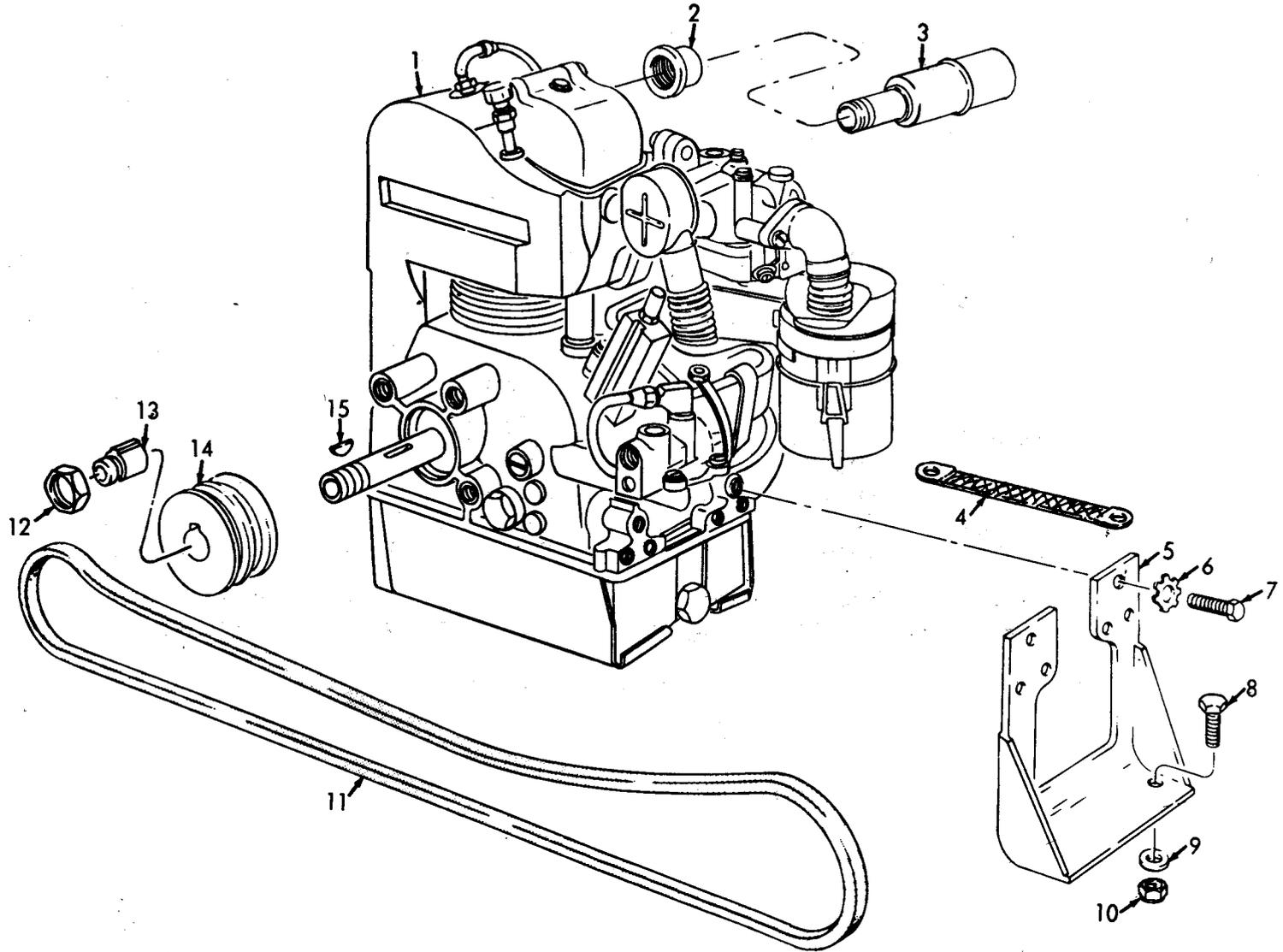

ME 4310-241-35P/6

Figure 6. Engine, Bracket, Muffler, Oil Drain and Pulley.

INDEX TO PARTS, FIGURE 6

Reference Number	Functional Group	Item Name	Reference Number	Functional Group	Item Name
1	0100	ENGINE	9	0100	WASHER
2	0401	ADAPTER	10	0100	NUT
3	0401	MUFFLER	11	5007	BELT
4	1501	STRAP	12	0102	NUT
5	0100	BRACKET	13	0102	SLEEVE
6	0100	WASHER	14	0102	PULLEY
7	0100	SCREW	15	0102	KEY
8	0100	SCREW			

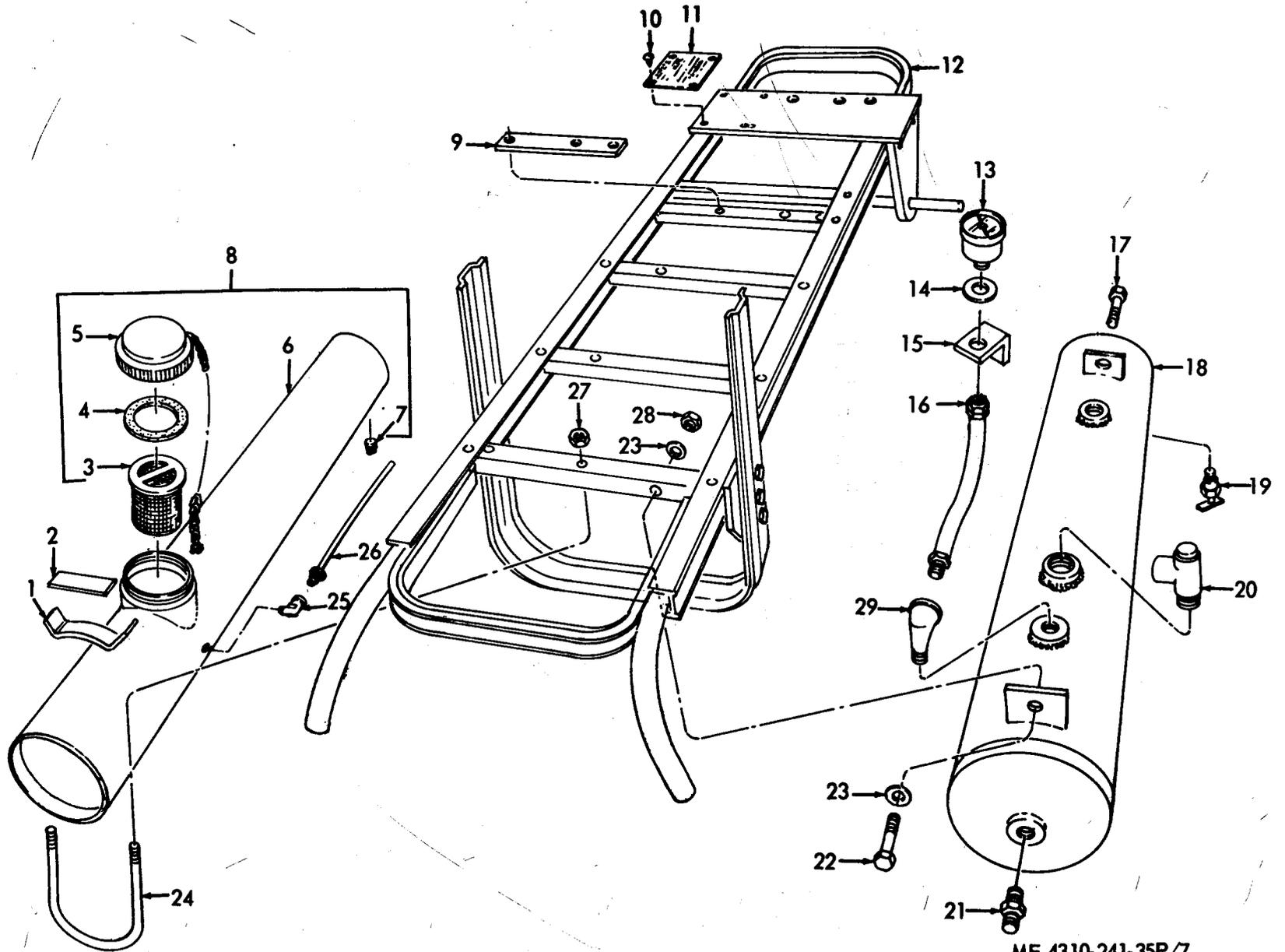

ME 4310-241-35P/7

Figure 7. Hand Truck, Gas Tank, Air Receiver, and Related Parts.

INDEX TO PARTS, FIGURE 7

Reference Number	Functional Group	Item Name	Reference Number	Functional Group	Item Name
1	0306	BRACKET	16	4702	HOSE AY
2	0306	STRIP	17	5014	BOLT
3	0306	STRAINER AY	18	5014	RECEIVER
4	0306	GASKET	19	5014	COCK
5	0306	CAP AND CHAIN	20	5014	VALVE
6	0306	TANK	21	5015	ADAPTER
7	0306	PLUG	22	5014	BOLT
8	0306	TANK AY	23	5014	WASHER
9	0100	SPACER	24	0306	BOLT
10	2210	SCREW	25	0306	ELBOW
11	2210	PLATE	26	0306	LINE AY
12	1501	HAND TRUCK AY	27	0306	NUT
13	4702	GAGE	28	5014	NUT
14	4702	WASHER	29	4702	ELBOW
15	4702	BRACKET			

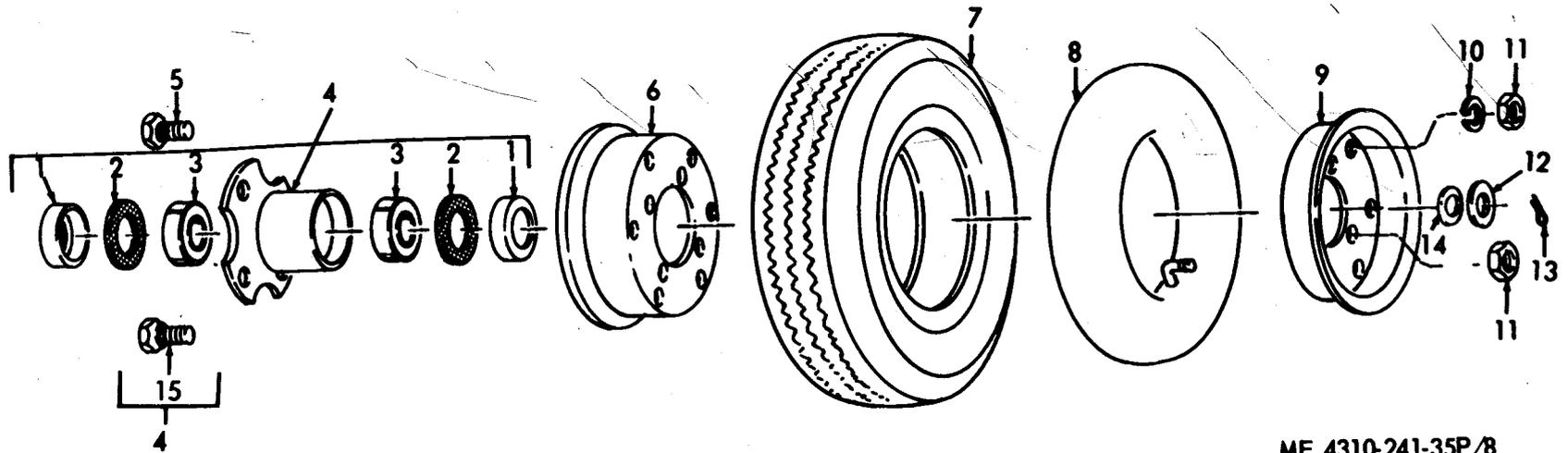

ME 4310-241-35P/8

Figure 8. Wheel, Tire, and Hub Assembly.

INDEX TO PARTS, FIGURE 8

Reference Number	Functional Group	Item Name	Reference Number	Functional Group	Item Name
1	1311	COVER	9	1311	DISK
2	1311	WASHER	10	1311	WASHER
3	1311	BEARING	11	1311	NUT
4	1311	HUB AY	12	1311	WASHER
5	1311	SCREW	13	1311	PIN
6	1311	DISK	14	1311	WASHER
7	1313	TIRE	15	1311	BOLT
8	1313	TUBE			

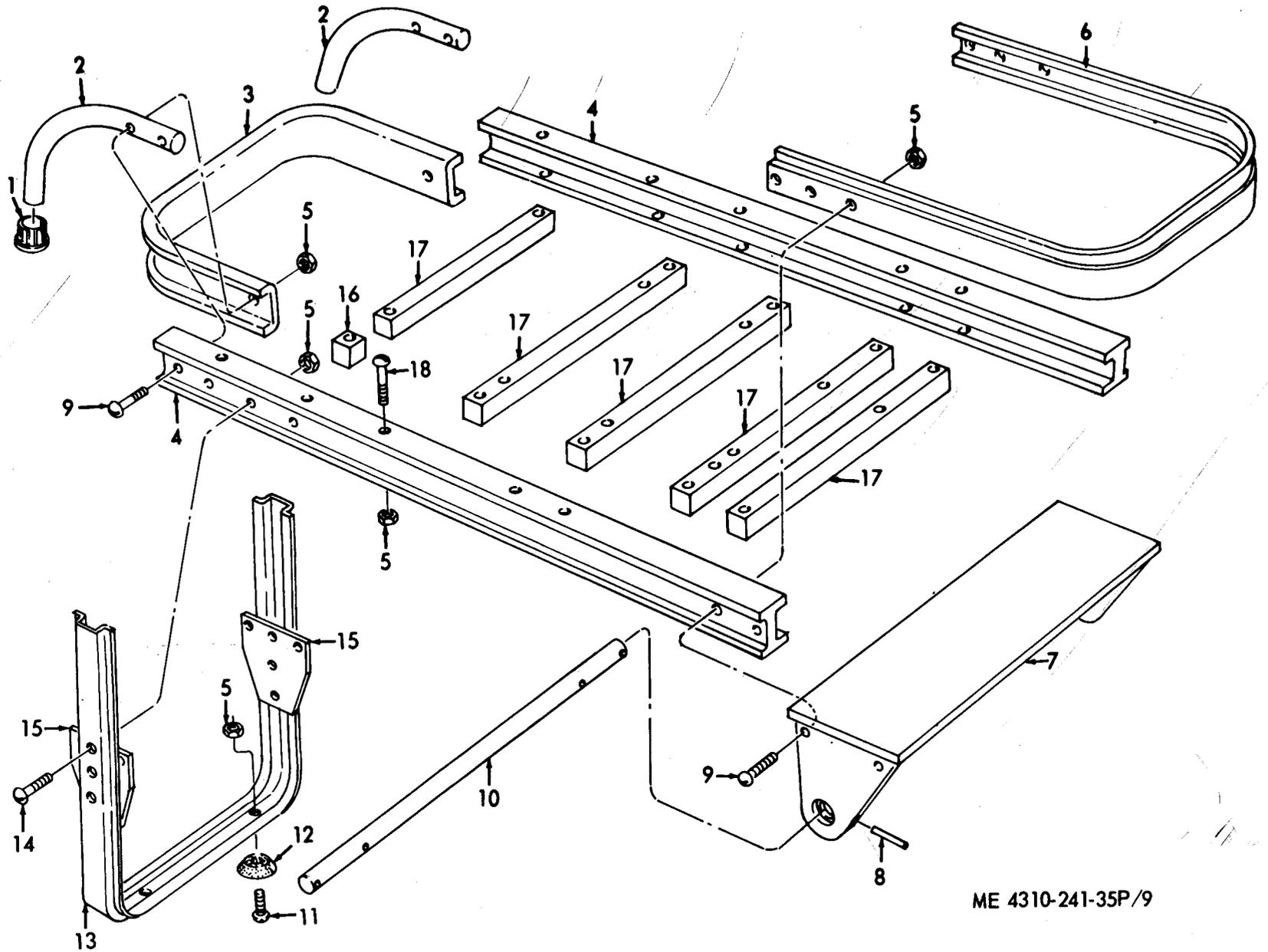

ME 4310-241-35P/9

Figure 9. Hand Truck Frame.

INDEX TO PARTS, FIGURE 9

Reference Number	Functional Group	Item Name	Reference Number	Functional Group	Item Name
1	1501	TIP	10	1000	AXLE
2	1501	HANDLE	11	1501	SCREW
3	1501	BUMPER	12	1501	FOOT
4	1501	RAIL	13	1501	LEG
5	1501	NUT	14	1501	SCREW
6	1501	BUMPER	15	1501	GUSSET
7	1501	NOSE	16	1501	SHIM
8	1000	PIN	17	1501	MEMBER
9	1501	SCREW	18	1501	SCREW

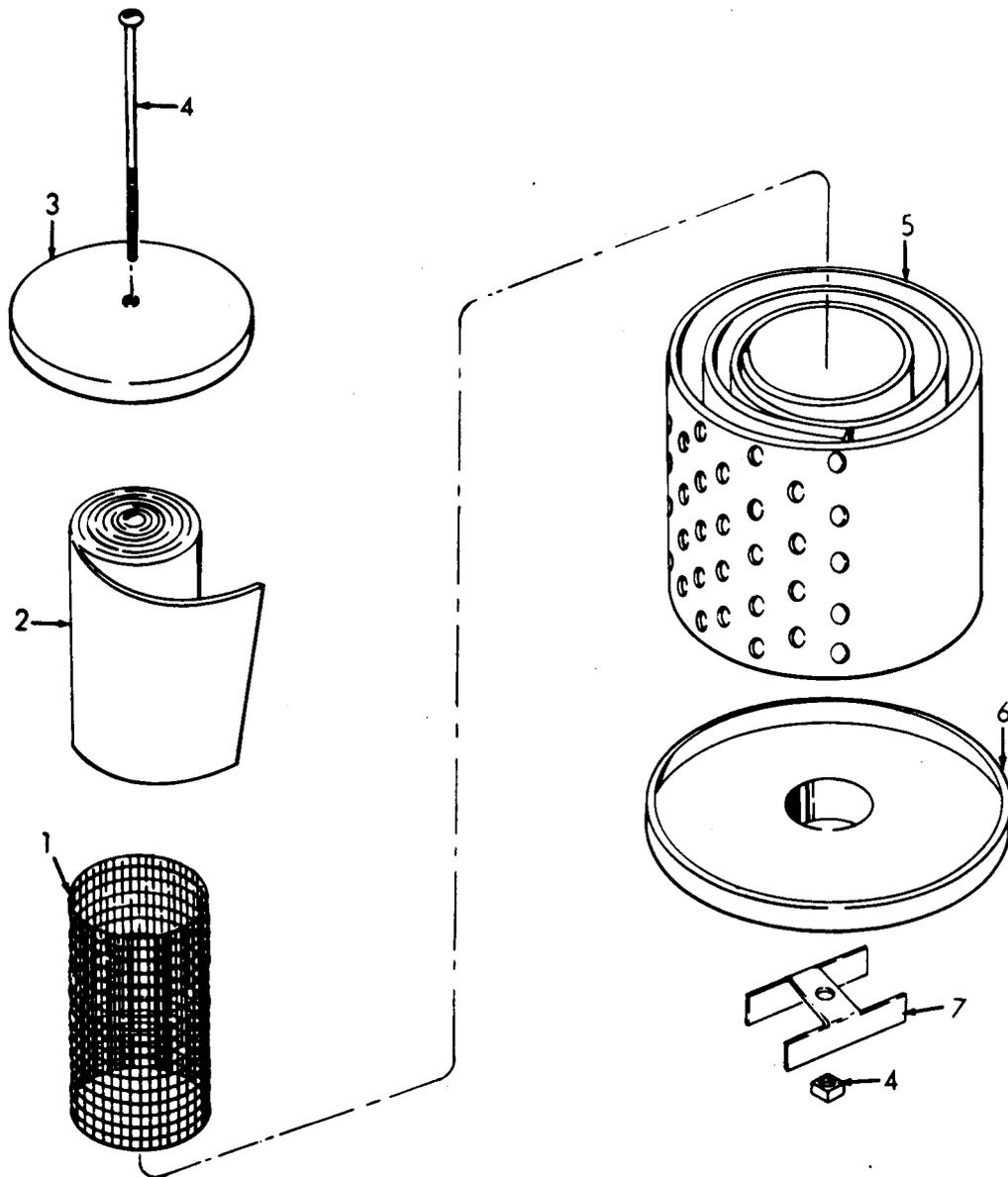

ME 4310-241-35P/10

Figure 10. Air Filter.

INDEX TO PARTS, FIGURE 10

Reference Number	Functional Group	Item Name	Reference Number	Functional Group	Item Name
1	5008	SCREEN	5	5008	PLATE
2	5008	ELEMENT	6	5008	COVER
3	5008	COVER	7	5008	CLAMP
4	5008	BOLT -NUT			

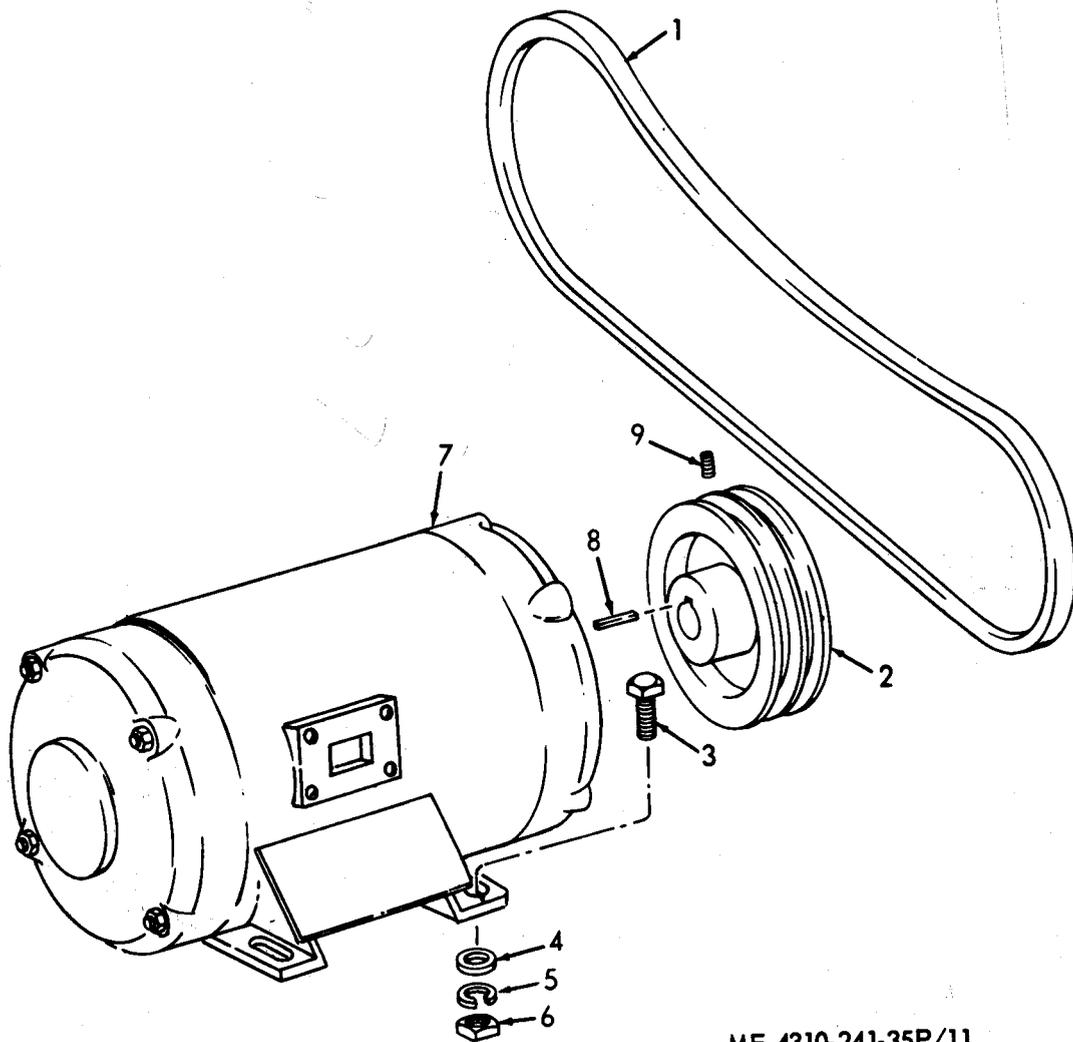

ME 4310-241-35P/11

Figure 11. Motor, Belt, and Pulley.

INDEX TO PARTS, FIGURE 11

Reference Number	Functional Group	Item Name	Reference Number	Functional Group	Item Name
1	5007	BELT	6	4000	NUT
2	4007	PULLEY	7	4000	MOTOR
3	4000	SCREW	8	4007	KEY
4	4000	WASHER	9	4007	SETSCREW
5	4000	WASHER			

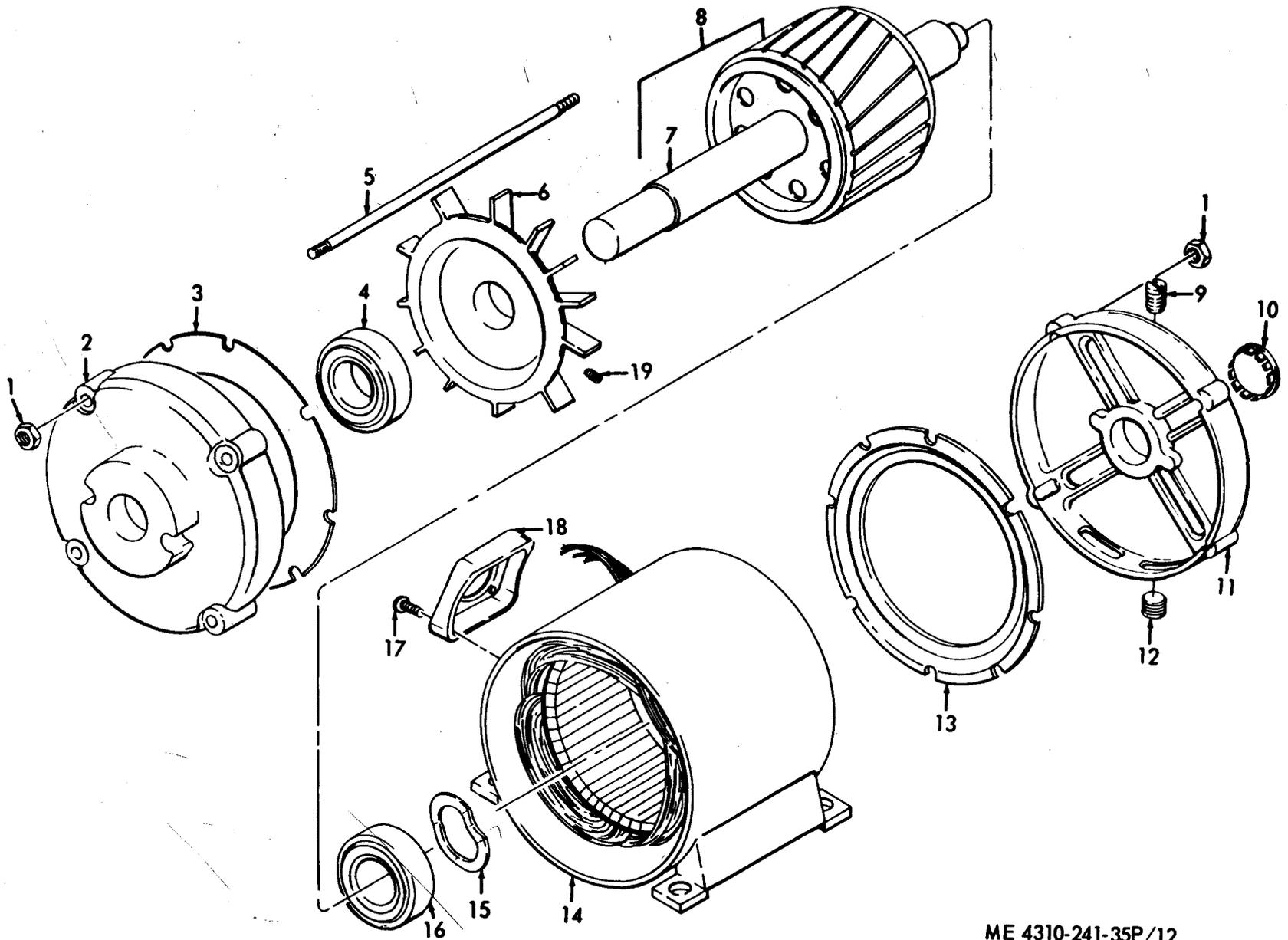

Figure 12. Electric Motor.

INDEX TO PARTS, FIGURE 12

Reference Number	Functional Group	Item Name	Reference Number	Functional Group	Item Name
1	4005	NUT	11	4005	BRACKET
2	4005	BRACKET	12	4005	PLUG
3	4004	BAFFLE	13	4004	BAFFLE
4	4005	BEARING	14	4002	FRAME AND STATOR
5	4005	BOLT	15	4005	WASHER
6	4004	FAN	16	4005	BEARING
7	4001	SHAFT	17	4005	SCREW
8	4001	ROTOR AY	18	4005	BASE
9	4005	PLUG	19	4004	SETSCREW
10	4005	BUTTON			

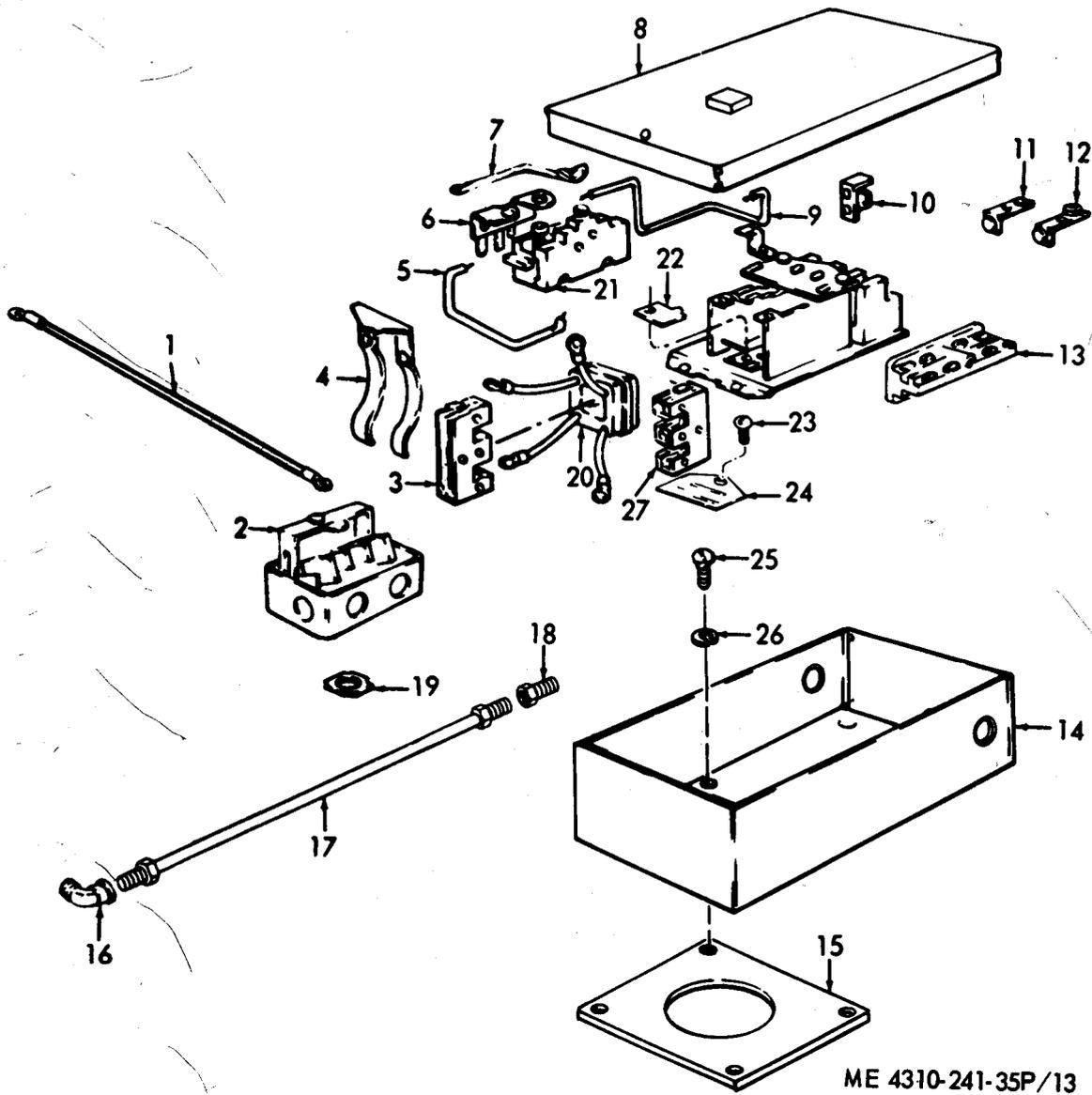
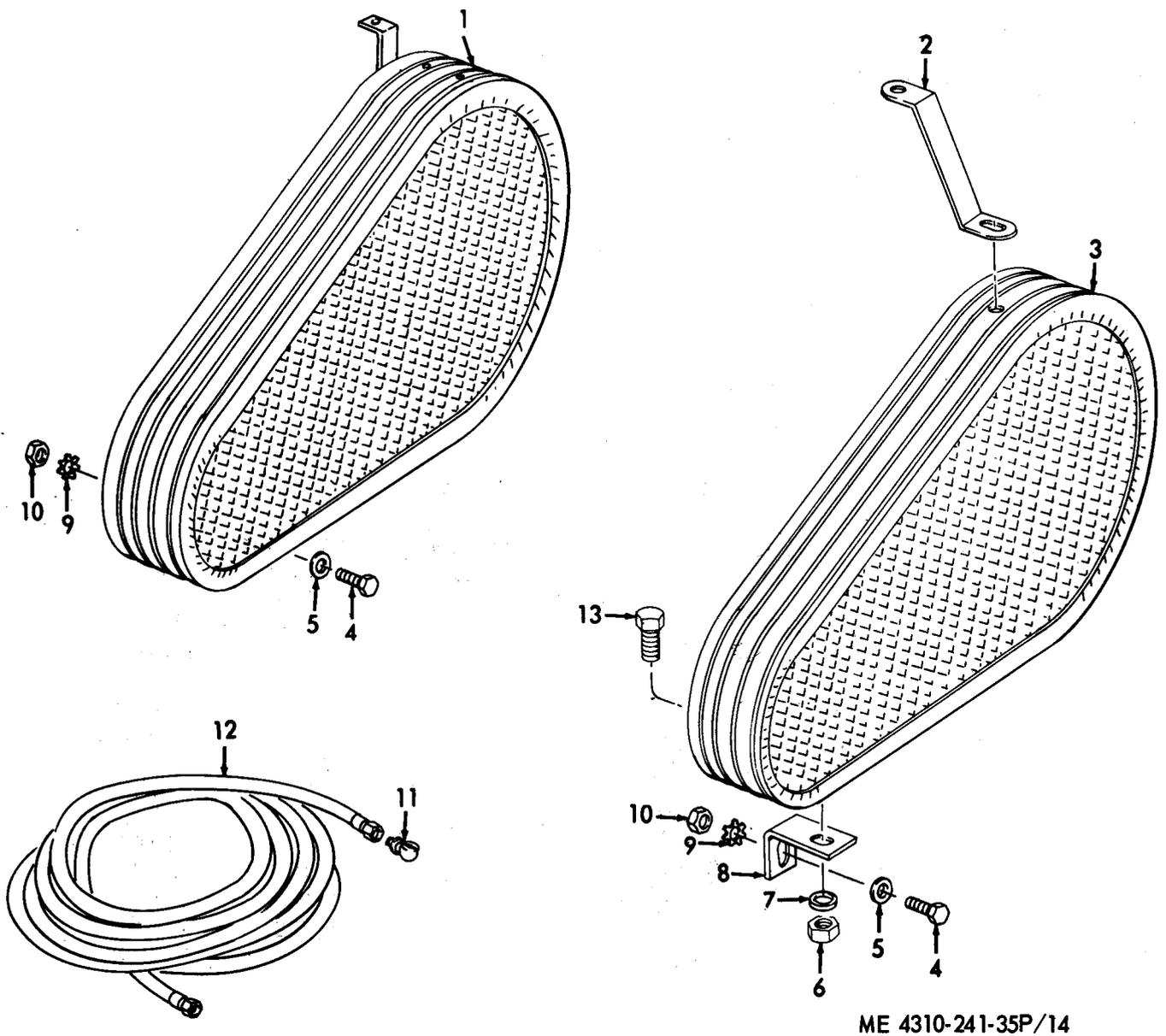

Figure 13. Magnetic Starter.

INDEX TO PARTS, FIGURE 13

Reference Number	Functional Group	Item Name	Reference Number	Functional Group	Item Name
1	4010	LEAD	15	4010	PLATE
2	4010	SWITCH	16	4010	ELBOW
3	4010	MAGNET	17	4010	TUBE
4	4010	SPRING	18	4010	ADAPTER
5	4010	LEAD	19	4010	LOCKNUT
6	4010	HEATER	20	4010	COIL
7	4010	LEAD	21	4010	RELAY
8	4010	COVER	22	4010	PLATE
9	4010	LEAD	23	2210	SCREW
10	4010	CONTACT AY	24	2210	PLATE
11	4010	CONTACT	25	4010	SCREW
12	4010	CONTACT	26	4010	WASHER
13	4010	RELAY	27	4010	MAGNET
14	4010	BOX			



ME 4310-241-35P/14

Figure 14. Compressor Drive Belt Guards, Bracket, and Mounting Hardware.

INDEX TO PARTS, FIGURE 14

Reference Number	Functional Group	Item Name	Reference Number	Functional Group	Item Name
1	5007	GUARD	8	5007	BRACKET
2	5007	BRACKET	9	5007	WASHER
3	5007	GUARD	10	5007	NUT
4	5007	SCREW	11	2202	CHUCK
5	5007	WASHER	12	2202	HOSE AY
6	5007	NUT	13	5007	BOLT
7	5007	WASHER			

INDEX TO PARTS, FIGURE 15

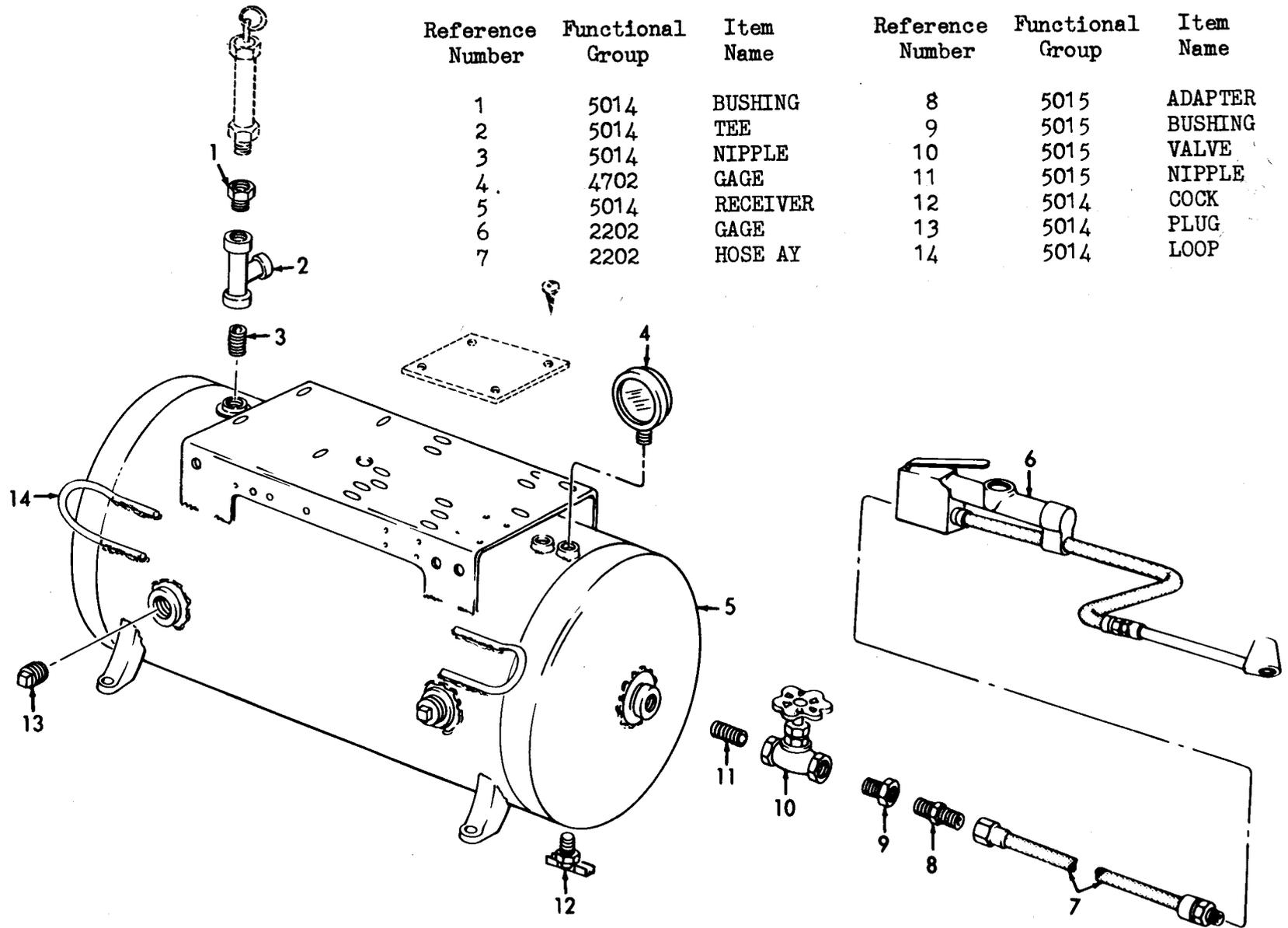

Reference Number	Functional Group	Item Name	Reference Number	Functional Group	Item Name
1	5014	BUSHING	8	5015	ADAPTER
2	5014	TEE	9	5015	BUSHING
3	5014	NIPPLE	10	5015	VALVE
4	4702	GAGE	11	5015	NIPPLE
5	5014	RECEIVER	12	5014	COCK
6	2202	GAGE	13	5014	PLUG
7	2202	HOSE AY	14	5014	LOOP

Figure 15. Air Tank, Valve, and Gage.

ME 4310-241-35P/15

SECTION IV INDEX-FEDERAL STOCK NUMBER AND REFERENCE NUMBER
 CROSS-REFERENCE TO INDEX NUMBER

STOCK NUMBER	INDEX NUMBER	STOCK NUMBER	INDEX NUMBER
2610-050-9560	00094	4310-631-9407	00746
2610-051-9114	00093	4310-633-6114	00404
2805-601-5181	00004	4310-633-6114	00611
2805-714-8552	00005	4310-646-9749	00507
2805-993-4199	00003	4310-646-9749	00516
2815-928-6078	00668	4310-646-9749	00749
2910-705-7814	00044	4310-649-8396	00493
2910-992-6370	00045	4310-649-8397	00486
2920-064-8834	00133	4310-654-3588	00403
2920-834-8474	00341	4310-654-3588	00450
2990-269-7145	00055	4310-654-3589	00417
2990-863-0926	00643	4310-654-3589	00630
3020-837-1270	00236	4310-654-3589	00637
3030-243-7256	00553	4310-654-3590	00524
3030-251-3941	00554	4310-654-3592	00482
3110-144-8534	00466	4310-654-3593	00478
3110-144-8589	00198	4310-657-7413	00399
3110-144-8589	00199	4310-657-7413	00406
3110-144-8589	00200	4310-657-7413	00447
3110-144-8622	00197	4310-799-0812	00433
3110-144-8648	00196	4310-811-6046	00502
3110-144-8648	00201	4310-819-4222	00020
3110-586-8305	00468	4310-828-8558	00018
3110-586-8306	00469	4310-837-1359	00582
3110-606-8365	00413	4310-838-9846	00561
3110-606-8365	00601	4310-839-6555	00097
3110-606-8365	00626	4310-850-5541	00646
4310-025-6328	00470	4310-860-0035	00560
4310-065-9622	00558	4310-873-1767	00144
4310-066-4206	00405	4310-874-3179	00142
4310-066-4950	00489	4310-874-3179	00143
4310-066-6039	00496	4310-874-3181	00685
4310-075-1685	00663	4310-874-3181	00686
4310-327-6438	00390	4310-874-3181	00687
4310-329-8426	00538	4310-875-4108	00709
4310-532-7791	00701	4310-877-2622	00625
4310-555-4540	00511	4310-877-2625	00244
4310-585-4283	00400	4310-882-5057	00398
4310-585-4283	00608	4310-884-4518	00606
4310-585-7546	00409	4310-884-4582	00612
4310-585-7546	00448	4310-887-2622	00412
4310-585-9951	00401	4310-887-8764	00432
4310-585-9951	00449	4310-887-8765	00137
4310-616-4372	00530	4310-896-2104	00644
4310-616-4372	00537	4310-896-2105	00655
4310-616-4373	00632	4310-896-5984	00603
4310-616-4373	00645	4310-899-1275	00544
4310-616-4374	00419	4310-902-2447	00397
4310-625-6748	00418	4310-930-2561	00698
4310-625-6748	00631	4310-930-8106	00509
4310-625-6748	00642	4310-934-8196	00596
4310-625-6749	00414	4310-961-3666	00670
4310-625-6749	00602	4310-961-3667	00664
4310-625-6749	00627	4310-976-0783	00500
4310-625-6752	00529	4310-977-2549	00548
4310-625-6753	00526	4310-977-2549	00623
4310-625-6754	00536	4310-977-8670	00678
4310-631-3396	00525	4310-980-0140	00589
4310-631-3397	00532	4310-986-9683	00617
4310-631-9407	00501	4310-987-2742	00394
4310-631-9407	00510	4310-993-4188	00585

SECTION IV. INDEX-FEDERAL STOCK NUMBER AND REFERENCE NUMBER
 CROSS-REFERENCE TO INDEX NUMBER (CONTINUED)

STOCK NUMBER	INDEX NUMBER	STOCK NUMBER	INDEX NUMBER
4310-993-4198	00587	5305-012-1279	00153
4310-999-6411	00590	5305-012-2159	00314
4710-277-5525	00032	5305-013-2740	00312
4710-277-5525	00034	5305-013-2740	00340
4710-277-5525	00036	5305-013-2740	00374
4710-277-5525	00619	5305-013-2764	00315
4710-277-5525	00622	5305-013-2892	00313
4710-277-5525	00738	5305-013-2900	00528
4710-277-7748	00675	5305-013-9412	00239
4710-277-7748	00739	5305-021-4389	00164
4710-278-6398	00379	5305-021-5450	00222
4710-278-6398	00550	5305-021-5466	00009
4710-278-6398	00737	5305-021-5466	00010
4720-807-8253	00029	5305-021-5466	00425
4730-011-8831	00220	5305-060-6800	00162
4730-018-9566	00047	5305-065-6800	00424
4730-044-4697	00216	5305-068-0502	00008
4730-050-1717	00728	5305-225-3839	00571
4730-142-1593	00031	5305-253-5612	00152
4730-142-1593	00378	5305-261-1868	00638
4730-142-1593	00549	5305-269-3211	00007
4730-142-1593	00618	5305-269-3213	00423
4730-196-2054	00037	5305-285-4531	00231
4730-202-6669	00725	5305-558-2679	00130
4730-202-6669	00727	5305-558-3679	00257
4730-221-3902	00027	5305-638-8908	00076
4730-228-1621	00439	5305-649-8115	00127
4730-246-9215	00385	5305-724-6810	00238
4730-257-2119	00699	5305-887-5666	00555
4730-257-5028	00688	5305-933-0184	00281
4730-277-8266	00327	5305-988-1170	00111
4730-277-8276	00243	5305-988-1725	00109
4730-277-8809	00726	5305-988-1725	00110
4730-277-9657	00691	5305-988-1725	00129
4730-277-9659	00692	5305-993-0184	00154
4730-277-9997	00451	5306-010-8503	00683
4730-278-3395	00217	5306-017-9818	00434
4730-278-3397	00219	5306-021-5371	00682
4730-278-3425	00218	5306-225-8497	00435
4730-287-0022	00694	5306-225-8497	00556
4730-288-1619	00442	5306-225-8499	00436
4730-288-9930	00241	5306-225-8499	00437
4730-288-9930	00542	5306-225-8503	00681
4730-289-1959	00039	5307-732-4920	00463
4730-289-1959	00621	5307-850-0308	00462
4730-365-0231	00072	5310-010-2635	00161
4730-391-3771	00722	5310-010-2635	00421
4730-391-3771	00723	5310-011-4604	00580
4730-684-4648	00684	5310-012-1753	00014
4730-850-7971	00660	5310-012-1753	00579
4730-851-6259	00672	5310-013-1099	00077
4820-274-7389	00730	5310-014-7697	00575
4820-888-9302	00710	5310-014-7697	00720
4910-202-2644	00138	5310-020-5186	00706
5305-010-0135	00163	5310-021-8585	00454
5305-010-2705	00599	5310-043-2226	00317
5305-011-3976	00708	5310-050-2234	00166
5305-012-0583	00224	5310-050-3267	00570
5305-012-0583	00225	5310-050-3275	00006
5305-012-1279	00151	5310-050-3275	00422

SECTION IV. INDEX-FEDERAL STOCK NUMBER AND REFERENCE NUMBER
 CROSS-REFERENCE TO INDEX NUMBER (CONTINUED)

STOCK NUMBER	INDEX NUMBER	STOCK NUMBER	INDEX NUMBER
5310-058-3651	00408	5940-050-6208	00302
5310-087-7493	00013	5940-681-9713	00248
5310-087-7493	00167	5940-681-9713	00267
5310-087-7493	00427	5945-020-6725	00279
5310-194-1540	00572	5945-020-6725	00339
5310-261-7340	00517	5945-020-6726	00280
5310-265-9215	00671	5950-532-7843	00286
5310-268-6154	00213	5950-532-7843	00321
5310-269-5914	00391	5975-152-1075	00273
5310-543-2629	00567	6105-877-2629	00158
5310-543-4488	00063	6105-887-4467	00172
5310-543-5653	00075	6105-887-4469	00157
5310-582-3341	00169	6105-887-8681	00173
5310-582-3341	00430	6110-532-7789	00246
5310-584-5005	00568	6110-532-7789	00328
5310-596-7691	00531	6110-757-1758	00265
5310-596-7691	00539	6110-877-2626	00289
5310-625-6755	00527	6110-877-2627	00287
5310-625-6755	00534	6110-883-4227	00263
5310-637-9541	00170	6110-883-4227	00288
5310-637-9541	00428	6110-883-4227	00324
5310-732-0558	00160	6110-883-4227	00343
5310-732-0558	00420	6110-883-4227	00356
5310-762-6213	00017	6110-887-2623	00260
5310-809-4058	00576	6110-887-2623	00353
5310-887-4598	00226	6110-887-2626	00261
5315-043-1787	00016	6110-887-2626	00322
5315-057-6607	00235	6110-887-2626	00344
5315-811-6491	00059	6110-887-2626	00354
5315-839-5822	00062	6110-887-2627	00262
5315-846-4881	00633	6110-887-2627	00323
5315-846-4888	00514	6110-887-2627	00342
5330-239-1792	00520	6110-887-2627	00355
5330-262-2543	00091	6110-887-4466	00245
5330-262-2543	00736	6110-887-4466	00329
5330-298-5554	00416	6110-887-4468	00229
5330-298-5554	00610	6110-887-4551	00284
5330-298-5554	00629	6110-887-4551	00318
5330-298-5674	00046	6110-887-4744	00350
5330-298-5674	00735	6145-160-5137	00296
5330-584-9000	00402	6145-160-5137	00299
5330-584-9000	00546	6145-160-5137	00303
5330-584-9010	00522	6145-160-5137	00331
5330-599-5888	00521	6145-160-5137	00742
5330-599-5888	00523	6145-161-5415	00270
5330-724-0793	00475	6145-161-5415	00305
5330-724-0793	00476	6145-161-5415	00741
5330-882-5056	00519	6145-191-2575	00272
5330-884-0705	00713	6145-192-2575	00740
5340-664-0403	00212	6145-295-1309	00293
5340-766-0331	00282	6145-295-1309	00332
5340-766-0331	00316	6145-542-6039	00249
5340-766-0331	00345	6145-542-6039	0268
5340-776-0331	00371	6150-894-1010	00190
5910-887-4654	00228	6680-377-4915	00464
5930-241-8921	00346	6685-264-3961	00387
5930-430-4071	00283	6685-264-3961	00388
5930-430-4071	00347	6685-264-3961	00389
5930-430-4071	00373	8305-262-2543	00074
5930-430-4071	00376	8305-430-9284	00042
5930-521-8471	00250	8305-430-9284	00743
5940-050-6207	00295	9510-229-0883	00205
5940-050-6207	00298	9510-229-0883	00734
5940-050-6207	00301	9905-807-3712	00149

SECTION IV. INDEX-FEDERAL STOCK NUMBER AND REFERENCE NUMBER
 CROSS-REFERENCE TO INDEX NUMBER (CONTINUED)

REFERENCE NO	MFG CODE	INDEX NO	REFERENCE NO	MFG CODE	INDEX NO
AA1485D	38151	00206	E1531-62R	38151	00165
AAC61406-66	38151	00179	E4850-6	38151	00215
AAC6276246	38151	00182	E60146-2C	38151	00184
AAF84E22G	38151	00175	E60146-3	38151	00187
AA61240AC	38151	00207	E60766-2	38151	00185
AA61475DC	38151	00210	E60766C	38151	00186
AA62931AC	38151	00209	E61477AC	38151	00189
AA62941AC	38151	00208	E7497-1	38151	00216
ACA126	21810	00286	E7497-3	38151	00214
ACA126	21810	00321	E7531-162	38151	00223
ACA151	21810	00260	E7531-62	38151	00221
ACA151	21810	00353	E7551-9R	38151	00213
AC84F25G23	38151	00173	E7848-17	83151	00199
AH84E40C10	38151	00172	E7848-35	83151	00196
AR3	21810	00341	FAO	21810	00360
AS61046-5	38151	00229	FIG112-4-200	75336	00649
AS61061-5	38151	00232	FIG112-200	75336	00648
AW14-6	11568	00071	FIG125-1-4-75LB	75336	00652
AW533	11568	00070	FIG125-70	75336	00650
AW586	11568	00068	FP175	71342	00719
A1560	11431	00078	FP7410	71342	00710
A4488-650	38151	00228	F12-6-208V	21810	00265
A60128-22R	38151	00204	F14-2	21810	00329
A60128-22S	38151	00202	F14-2-230V	21810	00245
A60128-42S	38151	00203	F28	21810	00328
A61212-3	38151	00195	F28-0-115V	21810	00246
A61212C	38151	00194	F4-0	21810	00361
A61351C	38151	00230	F538A	11568	00143
A61437DA	38151	00190	F7-1-416V	21810	00244
A61510-675	38151	00174	G1506	94894	00140
A61510-675	38151	00176	HA61551A	38151	00211
A61655-775	38151	00177	HL	23826	00347
A9913Y	21810	00259	H1	23826	00283
A9913Y	21810	00285	H1	23826	00373
A9913Y	21810	00320	H1	23826	00376
A9913Y	21810	00352	H8110P	11568	00644
A9917X	21810	00264	H122	11568	00411
A9917X	21810	00290	H18	11568	00473
A9917X	21810	00325	H41P	11568	00705
B22-10	11568	00069	J501	11568	00564
B356-109	11568	00066	LL2-40	11568	00724
B356-110	11568	00067	LM48500	60038	00467
B5093	70925	00464	LM48510	60038	00469
C6247V	21810	00277	LM48548	60038	00468
C6247V	21810	00309	L6248W2	21810	00261
C6247V	21810	00367	L6248W2	21810	00289
C6247W	21810	00337	L6248W2	21810	00322
C9906W	21810	00278	L6248W2	21810	00344
C9906W	21810	00310	L6248W2	21810	00354
C9906W	21810	00338	L6289L2	21810	00262
C9906W	21810	00368	L6289L2	21810	00287
D274-1	23826	00252	L6289L2	21810	00323
D354-1	23826	00253	L6289L2	21810	00342
D334-1	23826	00254	L6289L2	21810	00355
D358-1	23826	00256	L6290L2	21810	00263
D9805	23826	00251	L6290L2	21810	00343
EAC263298-5	38151	00180	L6290L2	21810	00356
EAC63298-5	38151	00181	L6290L2	21810	00288
EA60146C1C	38151	00188	L7030W1	21810	00275
EA71974B	38151	00191	L7030W1	21810	00307

SECTION IV. INDEX-FEDERAL STOCK NUMBER AND REFERENCE NUMBER
 CROSS-REFERENCE TO INDEX NUMBER (CONTINUED)

REFERENCE NO	MFG CODE	INDEX NO	REFERENCE NO	MFG CODE	INDEX NO
L7030W1	21810	00334	M552	11568	00054
L7030W1	21810	00364	M554	11568	00725
L7030W2	21810	00274	M567	11568	00438
L7030W2	21810	00306	M606	11568	00024
L7030W2	21810	00333	M607	11568	00023
L8833L3	21810	00279	M617	11568	00011
L8833L3	21810	00311	M617	11568	00012
L8833L3	21810	00339	M62	11568	00593
L8833L3	21810	00369	M627	11568	00696
L8833L4	21810	00280	M629	11568	00685
L8833L4	21810	00370	M632	11568	00589
L9290L2	21810	00324	M633	11568	00592
MS35338-8	96906	00168	M634	11568	00020
MS35338-8	96906	00429	M636	11568	00583
MS35389-1	96906	00094	M640	11568	00133
MS35392-48	96906	00093	MS641	11568	00384
M122	11568	00416	M645	11568	00148
M122	11568	00610	M651	11568	00117
M27	11568	00365	M657	11568	00115
M27	11568	00547	M694	11568	00028
M27	11568	00624	NR104	11568	00636
M30	11568	00585	NR15	11568	00456
M30L	11568	00586	NR150	11568	00394
M31	11568	00587	NR150A	11568	00395
M31L	11568	00588	NR150AL	11568	00396
M32	11568	00595	NR150L	11568	00397
M408	11568	00351	NR2	11568	00670
M408	11568	00541	NR2AB	11568	00664
M449B	11568	00703	NR2ABL	11568	00663
M450A	11568	00704	NR2B	11568	00662
M453A	11568	00709	NR2BL	11568	00661
M454	11568	00707	NR2L	11568	00669
M456	11568	00163	NR31	11568	00409
M459	11568	00545	NR31	11568	00448
M460	11568	00452	NR4-1H	11568	00673
M461	14959	00440	NR4-1H	11568	00676
M462	11568	00598	NR4-1P	11568	00674
M466	11568	00654	NR4-105	94834	00569
M467	11568	00504	NR4-5	11568	00470
M467	11568	00513	NR4-5AB	11568	00471
M468	11568	00508	NR4-5B	11568	00472
M472	11568	00638	NR4-7	11568	00560
M498	11568	00236	NR4-7L	11568	00561
M499	11568	00359	NR4-80B	11568	00615
M501	11568	00565	NR4-80BL	11568	00614
M501A	11568	00557	NR4-9	11568	00443
M501B	11568	00558	NR4-9L	11568	00445
M501D	11568	00559	NR47	11568	00562
M501L	11568	00563	N06X1-2	87764	00040
M502A	11568	00003	N060	11568	00386
M508	11568	00543	N39	11568	00507
M519	11568	00388	N39	11568	00516
M519C	11568	00387	PF1205D	14959	00689
M519C	11568	00389	PF13J	14959	00453
M52	11568	00584	PF33	14959	00441
M523	11568	00730	PF604B	26403	00727
M538A3	11568	00033	PK55	23826	00250
M538A36	11568	00035	PPMSM	11568	00147
M54B	11568	00591	P2202B	11568	00698
M54BL	11568	00590	P2249B	11568	00097

SECTION IV. INDEX-FEDERAL STOCK NUMBER AND REFERENCE NUMBER
 CROSS-REFERENCE TO INDEX NUMBER (CONTINUED)

REFERENCE NO	MFG CODE	INDEX NO	REFERENCE NO	MFG CODE	INDEX NO
RE10-100	11568	00606	SE30-18	11568	00546
RE10-100L	11568	00605	SE30-20	11568	00503
RE10-24	11568	00506	SE5-10A	11568	00498
RE10-3A	11568	00505	SE5-10B	11568	00497
RE10-37	11568	00502	SE5-10C	11568	00499
RE10-62	11568	00527	SE5-2A	11568	00668
RE10-62	11568	00534	SE5-2AB	11568	00597
RE10-66	11568	00520	SE5-2ABL	11568	00596
RE10-99	11568	00659	SE5-2C	11568	00667
RE12	11568	00677	SE5-2CL	11568	00665
RE14-104	11568	00635	SE5-2C1	11568	00666
RE20-106	11568	00639	SE5-20	11568	00512
RE4-12	11568	00679	SE5-21A	11568	00483
RE4-12A	11568	00678	SE5-28	11568	00521
RE4-6B	11568	00433	SE5-3A	11568	00515
RE4-6BL	11568	00432	SE5-37	11568	00511
RE4-80A	11568	00616	SE5-38	11568	00501
RE4-80AL	11568	00613	SE5-38	11568	00510
RE4-9A	11568	00446	SE5-4C	11568	00484
RE4-9AL	11568	00444	SE5-78	11568	00461
RE7-10A	11568	00491	SE5-8	11568	00474
RE7-10B	11568	00490	SE5-82	11568	00655
RE7-10C	11568	00492	SE5-82A	11568	00656
RE7-21C	11568	00479	SE5-836B	11568	00643
RE7-4C	11568	00480	SE5-85	11568	00415
RE7-52A	11568	00533	SE5-85	11568	00604
RE7-53A	11568	00526	SE5-85	11568	00628
RE7-56A	11568	00536	SE5-86A	11568	00417
RE7-57A	11568	00529	SE5-86A	11568	00630
RE7-58	11568	00538	SE5-86A	11568	00637
RE7-60	11568	00530	SE5-87	11568	00612
RE7-60	11568	00537	SE5-88	11568	00408
RE7-81	11568	00535	SE5-88	11568	00609
SB254	11568	00617	SE5-88	11568	00653
SD494	11568	00065	SE5-90	11568	00646
SE14-15	11568	00457	SE5-91	11568	00419
SE14-15B	11568	00458	SE5-91	11568	00632
SE14-15B	11568	00460	SE5-91	11568	00645
SE14-15BL	11568	00459	SE5-92A	11568	00634
SE14-15L	11568	00455	SE5-94	11568	00640
SE14-29	11568	00399	SE5-95	11568	00413
SE14-29	11568	00406	SE5-95	11568	00601
SE14-29	11568	00447	SE5-95	11568	00626
SE14-30A	11568	00404	SE5-97	11568	00418
SE14-30A	11568	00410	SE5-97	11568	00631
SE14-30A	11568	00611	SE5-97	11568	00642
SE14-31	11568	00401	SE5-98	11568	00657
SE14-31	11568	00449	SE572	11568	00463
SE14-33	11568	00403	T108	23826	00255
SE14-33	11568	00450	T1014	91895	00731
SE14-84	11568	00641	UB641	UB254	00548
SE14-89	11568	00400	UB254	11568	00620
SE14-89	11568	00407	U8	11568	00234
SE14-89	11568	00608	VB254	11568	00552
SE254	11568	00623	WD9920W	21810	00146
SE30-101	11568	00414	WD9920W	21810	00291
SE30-101	11568	00602	WD9920W	21810	00326
SE30-101	11568	00627	WD9920W	21810	00358
SE30-17	11568	00544	X261-15	11568	00131
SE30-18	11568	00402	X9389X	21810	00308

SECTION IV. INDEX-FEDERAL STOCK NUMBER AND REFERENCE NUMBER
 CROSS-REFERENCE TO INDEX NUMBER (CONTINUED)

REFERENCE NO	MFG CODE	INDEX NO	REFERENCE NO	MFG CODE	INDEX NO
Y9389X	21810	00150	Z67-70	75336	00651
Y9389X	21810	00276	Z7-4C	1568	00478
Y9389X	21810	00336	Z9917X	21810	00357
Y9389X	21810	00366	OSN4	11568	00475
ZDA26-73	73559	00381	1-2-20N	87764	00706
Z10-3A	11568	11500	1-2CLN	74545	00335
Z100G	11568	00519	1-2CN	11568	00729
Z113	11568	00532	1-2T	86285	00700
Z114	11568	00524	1-2X1-5	11568	00690
Z115	11568	00525	1-4ETL	79807	00579
Z124	11568	00412	1-4FW	79807	00572
Z124-150	11568	00625	1-4LW	79807	00577
Z177A	11568	00493	1-4W	79807	00051
Z177B	11568	00496	1-4W	79807	00574
Z187A	11568	00486	1-4X1-490DEGCE	87005	00327
Z187B	11568	00489	1-4X1-8SCB	87005	00319
Z206-200	75336	00647	1-4X101-2TA	11568	00377
Z220A	11568	00701	1-4X8	11568	00375
Z220B	11568	00702	1-4X8-1-2AT	11568	00348
Z253	11568	00398	1A08-1	81336	00004
Z253A	11568	00405	1A08-2	81336	00005
Z257	11568	00043	10TW80CSTR	21810	00362
Z257-1	11568	00049	10TW90CSOL	21810	00363
Z257-2	11568	00044	10TW90DEGCSOL	21810	00271
Z257-3	11568	00045	10TW90DEGCSOL	21810	00332
Z257-4	11568	00048	11-14	87005	00621
Z260	11568	00390	1136G34	86823	00697
Z261-1	11568	00107	1136H34	11568	00695
Z261-1A	11568	00126	14TW4	11568	00330
Z261-10	11568	00108	14TW80CSTR	21810	00266
Z261-10	11568	00128	14TW80DEGC	21810	00331
Z261-13	11568	00123	15-4A	87005	00607
Z261-17	11568	00064	1825A	92976	00686
Z261-17	11568	00134	1825A	92976	00687
Z261-18	11568	00100	184CSR29BBCW	38151	00157
Z261-19	11568	00113	184P4R2158	38151	00159
Z261-19	11568	00132	184TSR27BB	38151	00158
Z261-2	11568	00104	189D1-4X1-8	30327	00242
Z261-2A	11568	00121	2-1-2X1-1-2-2AL	11568	00018
Z261-20	11568	00101	2DA25-73	73559	00346
Z261-20	11568	00118	2DA25-73	73559	00372
Z261-3	11568	00102	20B263	11568	00487
Z261-3	11568	00119	2030	79150	00629
Z261-4	11568	00099	21-2X3-42VA	11568	00019
Z261-5	11568	00098	212W112	80201	00476
Z261-5A	11568	00116	2165	79150	00522
Z261-6	11568	00105	2185	79150	00523
Z261-6A	11568	00122	29NE040	72962	00038
Z261-7	11568	00112	29NE040	72962	00106
Z261-8	11568	00103	29NE040	72962	00124
Z261-8	11568	00120	29NE058	72962	00125
Z261-9	11568	00058	29NE058	11568	00693
Z261B	11568	00114	3-4X1-2CRW	74545	00349
Z5-3A	11568	00509	3-8-16X1-1-4CS	87764	00162
Z5-4C	11568	00482	3-8-16X1-1-4CS	87764	00424
Z538	11568	00144	3-8-16X3-8SS	11568	00239
Z538A	11568	00142	3-8FN	79807	00166
Z60A	11568	00603	3-8LW	11568	00169
Z64A	11568	00594	3-8LW	11568	00430
Z64L	11568	00582	3-8N	87764	00161

SECTION IV. INDEX-FEDERAL STOCK NUMBER AND REFERENCE NUMBER
 CROSS-REFERENCE TO INDEX NUMBER (CONTINUED)

REFERENCE NO	MFG CODE	INDEX NO	REFERENCE NO	MFG CODE	INDEX NO
3-8N	87764	00421	6461	11431	00083
306	11431	00080	6711	71342	00718
307	11431	00086	699	94894	00137
3207	43334	00466	71048	11568	00488
4L540-2	25472	00553	72B507	11568	00495
4L580-2	25472	00554	7224874	21810	00282
4201	11431	00081	7224874	21810	00316
4204AA12J201-26	21810	00284	7224874	21810	00345
4204AA12J201-26	21810	00318	730DCTDRC	08070	00141
4204AA13J201-51	21810	00258	730DCTDRG	08070	00139
4204AA13J201-51	21810	00350	7300CTDRC	08070	00138
4216	11431	00089	7392	71342	00712
4219	11431	00084	7394	71342	00714
5-1-4X7-82VA	11568	00237	7396	71342	00713
5-16N	11568	00566	7404	71342	00711
5-16W	11568	00573	77503	43334	00198
5-166W	11568	00578	77503	43334	00200
5L19217	11568	00025	77505	43334	00197
5000-75	97464	00481	77507	43334	00201
5000-93	97464	00485	8R	72800	00026
559	11431	00079	841	11431	00088
6ETL	79807	00051	89966	08645	00055
6381	71342	00717	91-20281	11568	00494
6382	71342	00715	919	11431	00090
6383	71342	00716	954	11431	00087
6460	11431	00082	955	11431	00085

By Order of the Secretary of the Army:

W. C. WESTMORELAND,
General, United States Army,
Chief of Staff,

Official:

KENNETH G. WICKHAM,
Major General, United States Army,
The Adjutant General.

DISTRIBUTION:

To be distributed in accordance with DA Form 12-25, Section I, (qty rqr block no.A 7) direct and general support maintenance requirements for Air Compressors, 5 CFM.

* U. S. GOVERNMENT PRINTING OFFICE: 1969-344435/1145

TM 5-4310-241-35P COMPRESSOR, RECIPROCATING—1969